

Stress and deformation tensor

Author: Prof. Dr.-Ing. habil. Heinz Konietzky
(TU Bergakademie Freiberg, Geotechnical Institute)

1. Introduction.....	2
2. Tensors.....	3
2.1 Introduction	3
2.2 Pseudotensors	5
2.3 Special tensors	6
2.4 Typical tensor operations	7
2.5 Tensor analysis: simple examples	8
3. Stress tensor	10
4. Deformation tensor	24
5. Compatibility condition.....	31
6. Equilibrium conditions.....	33

1. Introduction

Geomechanical calculations have to consider the following 3 fundamental relations:

- Equilibrium conditions
- Compatibility conditions
- Constitutive laws

The coupling between the stresses and deformations is performed by the constitutive laws (material laws) as indicated by Fig. 1. In order to describe these relations effectively, the theory of tensors was developed at the end of the 19th century. During the 20th century, the use of tensors has extended beyond continuum mechanics and now includes among others the fields of special and general relativity, quantum mechanics, fluid mechanics and electromagnetism. In the context of geomechanics, we will use second-order tensors to describe stresses and deformations and fourth-order tensors to describe the constitutive laws. The scheme in Fig. 1 illustrates the interaction of the individual components, which are explained in more detail within the next chapters.

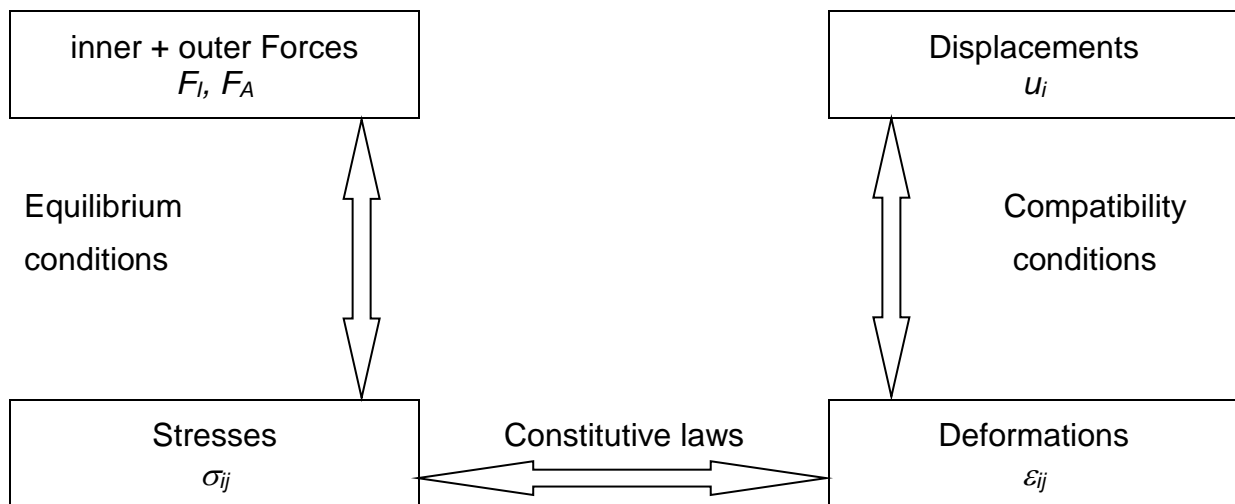

Fig.1.1: Geomechanical calculation scheme

2. Tensors

2.1 Introduction

Let's examine the known vector product in \mathbb{R}^3 . The vector product of two vectors produces a third vector

$$\mathbf{z} = \mathbf{w} \times \mathbf{x}, \quad \mathbf{z} \in \mathbb{R}^3 \quad 2.1$$

Understood as a function that maps $\mathbf{x} \rightarrow \mathbf{z}(\mathbf{x})$, the vector product is linear so that

$$\begin{aligned} \mathbf{w} \times (\alpha \mathbf{x}) &= \alpha (\mathbf{w} \times \mathbf{x}), \\ \mathbf{w} \times (\mathbf{x} + \mathbf{y}) &= (\mathbf{w} \times \mathbf{x}) + (\mathbf{w} \times \mathbf{y}) \end{aligned} \quad 2.2$$

We will call such a linear function a tensor, in this specific case a second-order tensor. Any linear function in \mathbb{R}^3 can be described through a multiplication with a matrix, so that we can write

$$\mathbf{z} = \mathbf{w} \times \mathbf{x} = \mathbf{W}\mathbf{x}, \quad \mathbf{W} \in \mathbb{R}^{3 \times 3} \quad 2.3$$

In the concrete case of the vector product, the matrix which describes the tensor takes the following form

$$\mathbf{W} = \begin{pmatrix} 0 & -w_3 & w_2 \\ w_3 & 0 & -w_1 \\ -w_2 & w_1 & 0 \end{pmatrix} \quad 2.4$$

Another example of a tensor is the rotation of a vector:

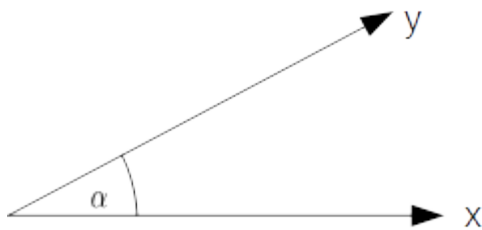

The rotation of a vector in \mathbb{R}^2 is a function which maps $\mathbf{x} \rightarrow \mathbf{y}(\mathbf{x})$. This function is once again linear

$$\begin{aligned} \mathbf{y}(m\mathbf{x}) &= m\mathbf{y}(\mathbf{x}) \\ \mathbf{y}(\mathbf{w} + \mathbf{x}) &= \mathbf{y}(\mathbf{w}) + \mathbf{y}(\mathbf{x}) \end{aligned} \quad 2.5$$

This function is therefore again called a (second-order) tensor and the rotation tensor can be described by means of matrix multiplication.

$$\mathbf{y}(\mathbf{x}) = \mathbf{Y}\mathbf{x} \tag{2.6}$$

With the rotation matrix

$$\mathbf{Y} = \begin{pmatrix} \cos \alpha & -\sin \alpha \\ \sin \alpha & \cos \alpha \end{pmatrix} \tag{2.7}$$

These two examples motivate the following definition: A multilinear function (i.e. a function which is linear in all its arguments) that acts on a vector and generates another vector is called a second-order tensor. Because vectors themselves can be used to represent linear functions, they can similarly be understood as tensors of a lower order, with our tensors of second order acting on these lower-order tensors. This leads to the following inductive, though highly abstract definition of tensors:

Tensors of the order $n = r + s$ are the multilinear functions between the two tensor spaces of the order r and s .

In the two examples given above, we discussed that second-order tensors can be described by matrices. Similarly, tensors of lower and higher order can be described by the generalization of matrices in different dimensions. This leads to the representation of tensors up to the fourth order in \mathbb{R}^3 as shown in Tab. 1.

In addition to this index notation, different types of tensors can be expressed by means of dashes above the symbols or parenthesis:

$\overset{_}{a}$		scalar	= zeroth-order tensor	
$\overset{_}{a}$	or	{a}	vector	= first-order tensor
$\overset{=}{a}$	or	[a]	3 × 3 matrix	= second-order tensor
...				

Because tensors are linear functions between vector spaces, every tensor can be expressed through components with respect to a basis of the vector spaces. Let's now examine what happens when we change the basis of the vector space on which the tensor operates.

Let's assume that $\mathbf{e}' = (e'_1, \dots, e'_n)$ and $\mathbf{e} = (e_1, \dots, e_n)$ are (ordered) bases of the n-dimensional vector space V . Every vector, including every basis vector can be described as a linear combination of the basis vectors.

$$e'_j = \sum_{i=1}^n a_{ij} e_i \tag{2.8}$$

This means that a change of basis is described through a series of coefficients a_{ij} . If T_{ij} are the components of the Tensor \mathbf{T} with respect to the basis \mathbf{e} , then, because of the linearity of tensors, we can obtain the components of \mathbf{T} with respect to \mathbf{e}' through

$$T'_{kl} = \sum_{i=1}^n \left(\sum_{j=1}^n a_{kj} a_{li} T_{ij} \right) \quad 2.9$$

with $k, l = 1, 2, \dots, n$, or using the shorter Summation Convention

$$T'_{kl} = a_{kj} a_{li} T_{ij} \quad 2.10$$

Tab. 1: Matrix and tensor definition (index notation)

symbol	matrix type	tensor order	no. of values	phys. example
a	scalar	zeroth	1	density
a_i	vector	first	3	displacement
a_{ij}	3×3	second	9	stress
a_{ijk}	$3 \times 3 \times 3$	third	27	--
a_{ijkl}	$3 \times 3 \times 3 \times 3$	fourth	81	stiffness matrix

Going forward, this summation will always be implied if an index appears twice in a multiplicative term. It is worth noting that there are different ways to define tensors. Occasionally, the described transformation behavior of the describing matrices is used as an equivalent definition to the one we used.

2.2 Pseudotensors

If tensors can be described through generalized matrices, one can ask the question why we bothered with our original definition, which is certainly less intuitive. In short, not everything that can be described as a n -dimensional matrix behaves like a tensor. For example, let's examine the permutation symbol, also called the Levi-Civita-symbol or ε -tensor. This symbol is defined by the sign of a permutation of the numbers 1, 2, ..., n for an integer n . The permutation symbol can be defined in any dimension greater than one. In two dimensions, it is

$$\varepsilon_{ij} = \begin{cases} +1 & \text{if } (i, j) = (1, 2) \\ -1 & \text{if } (i, j) = (2, 1) \\ 0 & \text{if } i = j \end{cases} \quad 2.11$$

and arranged into a 2×2 antisymmetric matrix:

$$\varepsilon_{ij} = \begin{pmatrix} 0 & 1 \\ -1 & 0 \end{pmatrix}. \quad 2.12$$

In three dimensions, it is,

$$\varepsilon_{ijk} = \begin{cases} +1 & \text{if } (i, j, k) = (1, 2, 3) \text{ or } (2, 3, 1) \text{ or } (3, 1, 2) \text{ (even permutations)} \\ -1 & \text{if } (i, j, k) = (3, 2, 1) \text{ or } (1, 3, 2) \text{ or } (2, 1, 3) \text{ (uneven permutations)} \\ 0 & \text{if } i = j, i = k, j = k \end{cases} \quad 2.13$$

The ε -tensor is completely antisymmetric (skew-symmetric):

$$\varepsilon_{123} = \varepsilon_{231} = \varepsilon_{312} = -\varepsilon_{321} = -\varepsilon_{132} = -\varepsilon_{213} = 1, \quad 2.14$$

all other elements are zero!

Arranged into a 3 x 3 x 3 matrix:

$$\varepsilon_{ijk} = \begin{matrix} & \begin{matrix} 0 & 1 & 0 \\ 1 & 0 & 0 \\ 0 & 0 & 1 \end{matrix} \\ \begin{matrix} 0 & 1 & 0 \\ 1 & 0 & 0 \\ 0 & 0 & 1 \end{matrix} & \begin{matrix} 0 & 1 & 0 \\ 1 & 0 & 0 \\ 0 & 0 & 1 \end{matrix} \end{matrix}, \quad 2.15$$

while the permutation symbol has a representation as a generalized matrix, it does not follow the transformation rules of a tensor. Under certain orthogonal transformations, for example a reflection in an odd number of dimensions, it should be multiplied by -1 if it were a tensor. However, the permutation symbol does not change at all and is therefore not a proper tensor.

2.3 Special tensors

Zero tensor:

All elements of the so-called zero tensor are zero:

$$\mathbf{a}_{ij} = \begin{pmatrix} 0 & 0 & 0 \\ 0 & 0 & 0 \\ 0 & 0 & 0 \end{pmatrix} \quad 2.16$$

Symmetric tensor:

A tensor is symmetric if non-diagonal elements are pairwise identical, e.g.: $a_{ij} = a_{ji}$, that means: $a_{12} = a_{21}$, $a_{23} = a_{32}$ and $a_{13} = a_{31}$.

Antisymmetric tensor:

A tensor is antisymmetric if non-diagonal elements are pairwise identical in absolute value, but with opposite sign,

e.g.: $a_{ij} = -a_{ji}$ for $i \neq j$, that means: $a_{12} = -a_{21}$, $a_{23} = -a_{32}$ and $a_{13} = -a_{31}$

2.4 Typical tensor operations

Transpose of a tensor (matrix):

The transposed matrix is created by reflection over the main diagonal or with other words: by writing rows as columns and vice versa.

$$\begin{pmatrix} a_{11} & \dots & a_{r1} \\ \vdots & \ddots & \vdots \\ a_{r1} & \dots & a_{rs} \end{pmatrix}^T = \begin{pmatrix} a_{11} & \dots & a_{r1} \\ \vdots & \ddots & \vdots \\ a_{1s} & \dots & a_{rs} \end{pmatrix} \quad 2.17$$

e.g.: $a_{ij}^T = a_{ji}$

$$\begin{pmatrix} a_{11} & a_{12} & a_{13} \\ a_{21} & a_{22} & a_{23} \\ a_{31} & a_{32} & a_{33} \end{pmatrix}^{-1} = \begin{pmatrix} a_{11} & a_{21} & a_{31} \\ a_{12} & a_{22} & a_{32} \\ a_{13} & a_{23} & a_{33} \end{pmatrix} \quad 2.18$$

Inverse of a tensor (matrix):

The product of a matrix and the corresponding invertible matrix results is the unit matrix (all diagonal elements = 1).

e.g.: $a_{ij} \cdot a_{ij}^{-1} = \delta_{ij}$ and $(a_{ij}^{-1})^{-1} = a_{ij}$ 2.19

Addition and Substraction of a tensor (matrix):

Only tensors of same rank can be added or subtracted. Sum or difference of two tensors of same rank is also a tensor of the same rank.

e.g.: $a_{i_1 \dots i_n} + b_{i_1 \dots i_n} = s_{i_1 \dots i_n}$ 2.20

Tensor product (cross product: $b \times c$):

$$a_i = \varepsilon_{ijk} \cdot b_j \cdot c_k \quad 2.21$$

Tensor product (dot product: $b \cdot c$):

The tensor product is obtained by simply multiplying components of two tensors together, pair by pair, so that the result of the product of a tensor with rank n with a tensor of rank m is a tensor of rank m+n.

$$a_{i_1 \dots i_m j_1 \dots j_n} = b_{i_1 \dots i_m} \cdot c_{j_1 \dots j_n} \quad 2.22$$

e.g.: $a_i \cdot b_{jk} = c_{ijk}$ 2.23

Determinant of a tensor (matrix):

$$|\mathbf{a}_{ij}| = \varepsilon_{ijt} a_{i1} a_{j2} a_{t3} = a_{11} a_{22} a_{33} + a_{21} a_{32} a_{13} + a_{31} a_{12} a_{23} - a_{11} a_{32} a_{23} - a_{12} a_{21} a_{33} - a_{13} a_{22} a_{31} \quad 2.24$$

Einstein's summation convention:

Summation over equal indices is performed:

$$\text{e.g.: } a_{ii} = a_{11} + a_{22} + a_{33} \quad 2.25$$

Replacement rule:

Change of indices (e.g. from k to l):

$$\text{e.g.: } a_i = \delta_{ik} a_k \quad 2.26$$

Contraction:

Contraction occurs either when a pair of literal indices of the tensor are set equal to each other and summed over or if during the multiplication of two tensors of order $n \geq 2$ one index of the left factor is equal to the right factor. In both cases the rank of the final tensor is reduced by two.

$$\text{e.g.: } \begin{array}{l} a_{ij} b_j = c_i \\ a_{ijk} b_{jq} = c_{ikq} \end{array} \quad \text{or} \quad a_{ikk} = b_k \quad \text{or} \quad \delta_{ij} a_{ijk} = b_k \quad 2.27$$

Derivative (comma convention):

The derivative with respect to another physical or geometrical quantity (coordinate, time etc.) is indicated by a comma:

$$\text{e.g.: } u_{i,j} = \frac{\partial u_i}{\partial x_j} \quad \text{or} \quad x_{i,tt} = \frac{d^2 x}{dt^2} \quad 2.28$$

2.5 Tensor analysis: simple examples

The following equations document the tensor handling with index notation.

$$a_{ii} = a_{11} + a_{22} + a_{33}$$

$$\sigma_{ij} = e_{ijkl} \cdot \varepsilon_{kl}$$

$$a_i \cdot b_j \cdot \delta_{ij} = a_i \cdot b_j = c$$

$$a_i = b_{ij} \cdot c_j$$

$$\mathbf{a}_{ij} = \mathbf{b}_{ik} \cdot \mathbf{c}_{kj}$$

$$\mathbf{a}_{ij}^T = \mathbf{a}_{ji}$$

$$[\mathbf{a}_{ij}^T]^T = \mathbf{a}_{ij}$$

$$\mathbf{a}_{ij} \cdot \mathbf{b}_{ji} = \mathbf{b}_{ij} \cdot \mathbf{a}_{ji} = \mathbf{c}$$

$$\mathbf{a}_{ij} \cdot \mathbf{a}_{ij}^{-1} = \mathbf{a}_{ij}^{-1} \cdot \mathbf{a}_{ij} = \mathbf{I}$$

$$\mathbf{a}_{ij} \cdot \delta_{ji} = \mathbf{a}_{ii} = \mathbf{b}$$

$$\mathbf{a}_{ij} \cdot \mathbf{a}_{kj} = \delta_{ik}$$

$$\mathbf{a}_{ik} \cdot \mathbf{b}_{ki} = \mathbf{a}_{1k} \cdot \mathbf{b}_{k1} + \mathbf{a}_{2k} \cdot \mathbf{b}_{k2} + \mathbf{a}_{3k} \cdot \mathbf{b}_{k3}$$

$$\mathbf{a}_i \cdot \mathbf{b}_i = \mathbf{a}_1 \cdot \mathbf{b}_1 + \mathbf{a}_2 \cdot \mathbf{b}_2 + \mathbf{a}_3 \cdot \mathbf{b}_3$$

$$\mathbf{a} = \mathbf{b}_{ijk} \cdot u_i \cdot v_j \cdot w_k$$

$$\mathbf{c}_{ik} = \mathbf{b}_{ij} \cdot \mathbf{b}_{kl} \cdot \mathbf{a}_{jl}$$

$$\mathbf{a}_{ijk} \cdot \mathbf{b}_{jl} = \mathbf{c}_{ikl}$$

$$\mathbf{a}_i \cdot \mathbf{b}_j = \mathbf{c}_{ij}$$

$$\mathbf{c}_i = \mathbf{b}_i - \mathbf{a}_i$$

$$\delta_{ij} \cdot \mathbf{a}_{ijk} = \mathbf{b}_{iik} = \mathbf{c}_k$$

$$\mathbf{b} = \mathbf{a}_{ik} \cdot \mathbf{a}_{jk} \cdot \mathbf{a}_{kl} \cdot \mathbf{a}_{lm} \cdot \mathbf{a}_{mi}$$

$$\mathbf{a}_{i,j} = \frac{\partial \mathbf{a}_i}{\partial x_j}$$

$$\partial \mathbf{s}^2 = \delta_{ij} \cdot dx_i \cdot dx_j$$

$$\varepsilon_{ijk} \cdot \varepsilon_{ijk} = 6$$

$$\mathbf{a}_2 = \varepsilon_{2jk} \cdot \mathbf{b}_j \cdot \mathbf{c}_k = \mathbf{b}_1 \cdot \mathbf{c}_3 - \mathbf{b}_3 \cdot \mathbf{c}_1$$

3. Stress tensor

Load is generated by outer forces F_A (area force) or inner force F_I (volume forces) according to Fig. 3.1.

For an arbitrary orientated cut a stress vector t is obtained, assuming that only forces and no moments are transferred. A denotes the area, where the force vector is considered.

$$t = \lim_{\Delta A \rightarrow 0} \left(\frac{F}{\Delta A} \right) \quad 3.1$$

The stress state can be defined in a cartesian coordinate system as illustrated in Fig. 3.2. Along the three faces of the cube three stress vectors t_1 , t_2 and t_3 can be obtained, whereby $\{\sigma_{i1}, \sigma_{i2}, \sigma_{i3}\}$ represent the three stress components on the particular cube faces (Fig. 3.2). In detail the stress tensor can be described as follows:

$$\sigma_{ij} = [t_1, t_2, t_3]^T = \begin{bmatrix} \sigma_{11} & \sigma_{12} & \sigma_{13} \\ \sigma_{21} & \sigma_{22} & \sigma_{23} \\ \sigma_{31} & \sigma_{32} & \sigma_{33} \end{bmatrix} = \begin{bmatrix} \sigma_{xx} & \tau_{xy} & \tau_{xz} \\ \tau_{yx} & \sigma_{yy} & \tau_{yz} \\ \tau_{zx} & \tau_{zy} & \sigma_{zz} \end{bmatrix} \quad 3.2$$

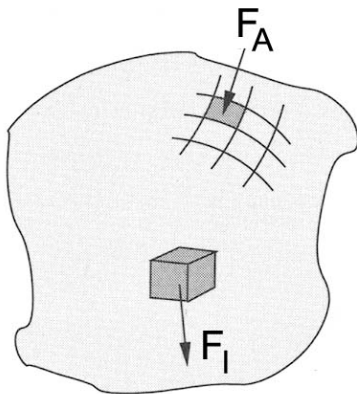

Fig. 3.1: Solid body with volume and area forces

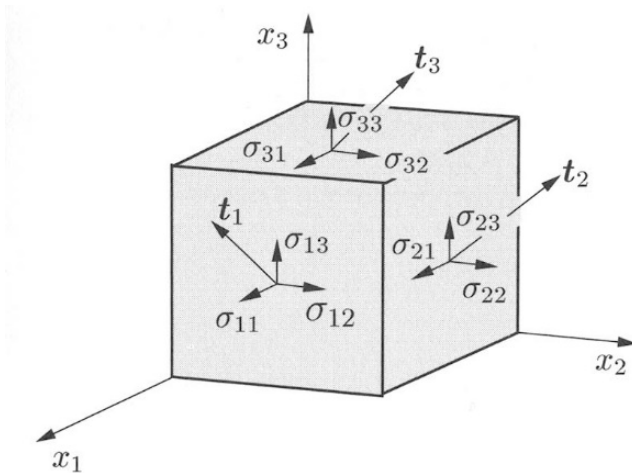

Fig. 3.2: 3-dimensional stress components at a cube

The first index specifies the normal of the particular face under consideration, the second index the impact direction of the stress component. According to eq. 3.2 the stress tensor consists of 9 elements. However, assumed that the sum of the moments is zero, pairwise identical shear stresses are obtained. This feature is also called ‘Boltzmann-Axiom’ and explained in more detail in Fig. 3.3 for the 2-dimensional case (the extension to 3D is straightforward) and by eq. 3.3.

$$\begin{aligned}
 \sum M_{xy} = 0 &= \tau_{xy} \cdot \Delta l \cdot 4\Delta l^2 - \tau_{yx} \cdot \Delta l \cdot 4\Delta l^2 & \Rightarrow & \tau_{xy} = \tau_{yx} \\
 \sum M_{xz} = 0 &= \tau_{xz} \cdot \Delta l \cdot 4\Delta l^2 - \tau_{zx} \cdot \Delta l \cdot 4\Delta l^2 & \Rightarrow & \tau_{xz} = \tau_{zx} \\
 \sum M_{yz} = 0 &= \tau_{yz} \cdot \Delta l \cdot 4\Delta l^2 - \tau_{zy} \cdot \Delta l \cdot 4\Delta l^2 & \Rightarrow & \tau_{yz} = \tau_{zy}
 \end{aligned}
 \tag{3.3}$$

From eq. 3.3 it follows, that the stress tensor is symmetric, that means:

$$\sigma_{ij} = \sigma_{ji} \quad \text{or} \quad \begin{matrix} = & =T \\ \sigma & = \sigma \end{matrix}
 \tag{3.4}$$

Therefore, the number of stress values is reduced from 9 to 6 (three pairwise identical shear stresses meaning no rotations). The relationship between stress vector and stress tensor is obtained on the basis of the equilibrium conditions in direction of the coordinates x_i (Fig. 3.4):

$$n_i = \cos(\bar{n}, x_i)
 \tag{3.5}$$

$$dA_i = n_i dA
 \tag{3.6}$$

where n_i is the unit normal vector.

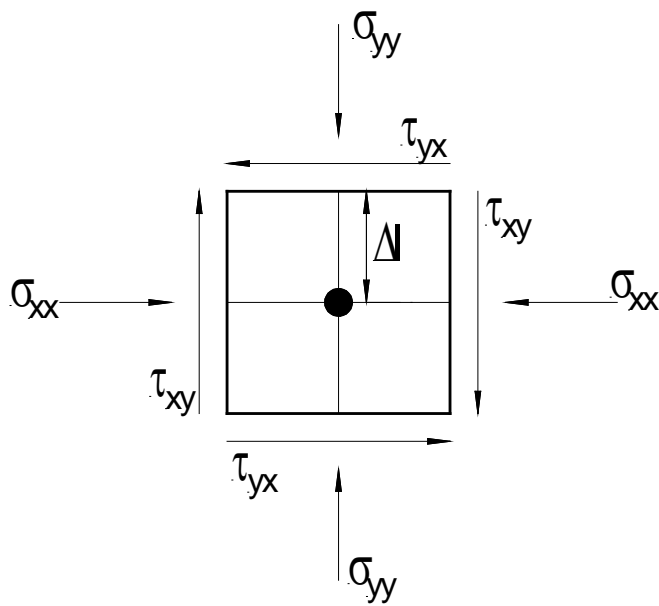

Fig. 3.3: Equilibrium considerations for a volume element (2D, x-y-plane)

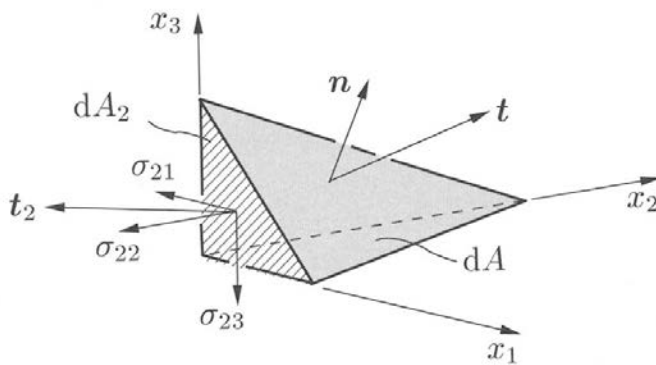

Fig. 3.4: Orientation of stress tensor and stress vector

Force equilibrium in 1-, 2- and 3-direction:

$$\begin{aligned}
 t_1 dA &= \sigma_{11} dA_1 + \sigma_{21} dA_2 + \sigma_{31} dA_3 \\
 t_2 dA &= \sigma_{12} dA_1 + \sigma_{22} dA_2 + \sigma_{32} dA_3 \\
 t_3 dA &= \sigma_{13} dA_1 + \sigma_{23} dA_2 + \sigma_{33} dA_3
 \end{aligned}
 \tag{3.7}$$

Using (3.5) and (3.6) eq. 3.7 can be simplified as follows:

$$\begin{aligned}
 t_1 &= \sigma_{11} n_1 + \sigma_{21} n_2 + \sigma_{31} n_3 \\
 t_2 &= \sigma_{12} n_1 + \sigma_{22} n_2 + \sigma_{32} n_3 \\
 t_3 &= \sigma_{13} n_1 + \sigma_{23} n_2 + \sigma_{33} n_3
 \end{aligned}
 \tag{3.8}$$

Equation 3.8 can be rewritten in tensor form as follows:

$$\begin{aligned} t_i &= \sigma_{ji} n_j = \sigma_{ij} n_j \\ &= \sigma_{ij} n_j = T_{ij} n_j \\ &= \sigma n = \sigma \cdot n \end{aligned} \quad 3.9$$

Equation 3.9 documents the equality of pairwise shear stresses. The so defined second-order stress tensor is called 'Cauchy stress tensor' or 'true' stress tensor or 'Euler stress tensor'. The Cauchy stress tensor σ_{ij} relates the current force vector to the current (deformed) area element.

$$dF_i = \sigma_{ji} dA_j \quad 3.10$$

F_i : current force vector

A_j : current area element with $dA_j = n_j dA$

Alternatively, the current force vector F_i can be related to the original area A° (that means before any deformation!). Such a stress tensor is called 'Nominal stress tensor', 'Lagrange stress tensor' or 'First Piola-Kirchhoff tensor' T_{ij} :

$$dF_i = T_{ji} dA_j^\circ \quad 3.11$$

The stress tensor can be decomposed into normal and shear components (n : normal vector; m : tangential vector) as illustrated by Fig. 3.5:

$$\sigma = n_i t_i = n_i \sigma_{ij} \cdot n_j \quad 3.12$$

or

$$\tau = m_i t_i = m_i \sigma_{ij} n_j \quad 3.13$$

In detail, equations 3.12 and 3.13 can also be written as:

$$\begin{aligned} \sigma &= n_1 \sigma_{11} n_1 + n_1 \sigma_{12} n_2 + n_1 \sigma_{13} n_3 \\ &\quad + n_2 \sigma_{21} n_1 + n_2 \sigma_{22} n_2 + n_2 \sigma_{23} n_3 \\ &\quad + n_3 \sigma_{31} n_1 + n_3 \sigma_{32} n_2 + n_3 \sigma_{33} n_3 \end{aligned} \quad 3.14$$

From equation 3.14 the following instances can be deduced:

$$n = \begin{pmatrix} 1 \\ 0 \\ 0 \end{pmatrix} \rightarrow \sigma_n = \sigma_{11} \text{ and}$$

$$n = \begin{pmatrix} 0 \\ 0 \\ 1 \end{pmatrix} \rightarrow \sigma_n = \sigma_{33}$$

For the shear stress follows:

$$\begin{aligned} \tau &= m_1 \sigma_{11} n_1 + m_1 \sigma_{12} n_2 + m_1 \sigma_{13} n_3 \\ &+ m_2 \sigma_{21} n_1 + m_2 \sigma_{22} n_2 + m_2 \sigma_{23} n_3 \\ &+ m_3 \sigma_{31} n_1 + m_3 \sigma_{32} n_2 + m_3 \sigma_{33} n_3 \end{aligned} \tag{3.15}$$

From equation 3.15 the following instances can be deduced:

$$n = \begin{pmatrix} 1 \\ 0 \\ 0 \end{pmatrix}; \quad m = \begin{pmatrix} 0 \\ 1 \\ 0 \end{pmatrix} \rightarrow \tau_n = \sigma_{21}$$

$$n = \begin{pmatrix} 0 \\ 0 \\ 1 \end{pmatrix}; \quad m = \begin{pmatrix} 0 \\ 1 \\ 0 \end{pmatrix} \rightarrow \tau_n = \sigma_{23}$$

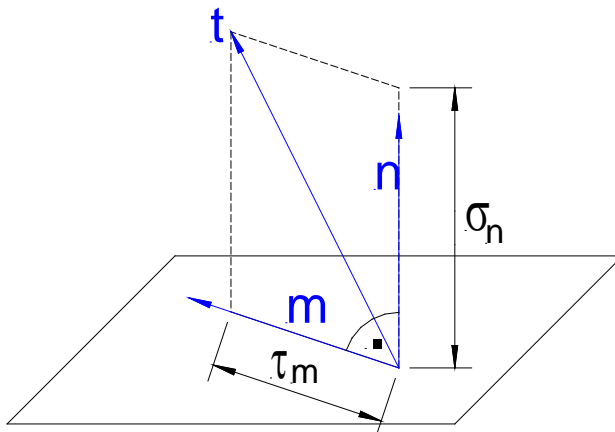

Fig. 3.5: Decomposition of stress vector \mathbf{t} into normal and shear stress component

If $\tau_n = m_i \sigma_{ji} n_j$, then:

$$n = \begin{pmatrix} 1 \\ 0 \\ 0 \end{pmatrix}; \quad m = \begin{pmatrix} 0 \\ 1 \\ 0 \end{pmatrix} \rightarrow \tau_n = \sigma_{12}$$

Thereby, it always holds: $n_i n_i = 1$ and $m_i m_i = 1$

Now we consider specific directions, where only normal stresses σ exist, but no shear stress τ . For such a constellation it holds:

$$t_i = \sigma_{ij} \cdot n_j \quad \text{and} \quad t_i = \sigma \cdot \delta_{ij} \cdot n_j, \quad 3.16$$

where n_j characterizes the principal stress directions. Equalization of both expressions in eq. 3.16 yields:

$$\sigma_{ij} \cdot n_j = \sigma \cdot \delta_{ij} \cdot n_j \quad \text{or} \quad (\sigma_{ij} - \delta_{ij} \cdot \sigma) n_j = 0 \quad 3.17$$

Equation 3.17 describes an eigenvalue problem with eigenvalues σ und n_j . The non-trivial solution is obtained if the coefficient determinant of eq. 3.18 vanishes:

$$\det(\sigma_{ij} - \sigma \delta_{ij}) = 0 \quad 3.18$$

or

$$\begin{vmatrix} \sigma_{11} - \sigma & \sigma_{12} & \sigma_{13} \\ \sigma_{12} & \sigma_{22} - \sigma & \sigma_{23} \\ \sigma_{13} & \sigma_{23} & \sigma_{33} - \sigma \end{vmatrix} = 0 \quad 3.19$$

The solution of equation 3.19 is a characteristic equation of third order:

$$\sigma^3 - I_1 \sigma^2 + I_2 \sigma - I_3 = 0, \quad 3.20$$

where the following holds:

$$I_1 = \sigma_{KK} = \sigma_{11} + \sigma_{22} + \sigma_{33} = \sigma_{ij} \delta_{ij}, \quad 3.21$$

$$\begin{aligned} I_2 &= \frac{1}{2} (\sigma_{ii} \sigma_{jj} - \sigma_{ij} \sigma_{ji}) = \begin{vmatrix} \sigma_{11} & \sigma_{12} \\ \sigma_{21} & \sigma_{22} \end{vmatrix} + \begin{vmatrix} \sigma_{11} & \sigma_{13} \\ \sigma_{31} & \sigma_{33} \end{vmatrix} + \begin{vmatrix} \sigma_{22} & \sigma_{23} \\ \sigma_{32} & \sigma_{33} \end{vmatrix}, \\ &= \sigma_{11} \sigma_{22} + \sigma_{22} \sigma_{33} + \sigma_{11} \sigma_{33} - \tau_{12}^2 - \tau_{23}^2 - \tau_{31}^2 \end{aligned} \quad 3.22$$

$$\begin{aligned} I_3 &= \det(\sigma_{ij}) = \frac{1}{3} \left(\frac{1}{2} \sigma_{ii} \sigma_{jj} \sigma_{KK} + \sigma_{ij} \sigma_{jK} \sigma_{Ki} - \frac{3}{2} \sigma_{ij} \sigma_{ji} \sigma_{KK} \right). \\ &= \sigma_{11} \sigma_{22} \sigma_{33} - \sigma_{11} \tau_{23}^2 - \sigma_{22} \tau_{13}^2 - \sigma_{33} \tau_{12}^2 + 2 \tau_{12} \tau_{23} \tau_{31} \end{aligned} \quad 3.23$$

The values I_1 , I_2 , I_3 are called ‘main invariants’ (I_1 : first main invariant, I_2 : second main invariant, I_3 : third main invariant) of the stress tensor, that means that they are independent of the coordinate systems (independent of translations or rotations of the reference system). Besides these main invariants there are the so called ‘basic invariants’, which can be considered as a special subset of the main invariants. They are defined as follows:

$$\begin{aligned}
 J_1 &= \sigma_{kk} = I_1 \\
 J_2 &= \frac{1}{2} \sigma_{ij} \sigma_{ji} = \frac{1}{2} I_1^2 - I_2 \\
 J_3 &= \frac{1}{3} \sigma_{ij} \sigma_{jk} \sigma_{ki} = \frac{1}{3} I_1^3 - I_1 I_2 + I_3
 \end{aligned}
 \tag{3.24}$$

Besides the cartesian representation it is also possible to find a formulation in form of the principal stresses:

$$\begin{aligned}
 I_1 &= \sigma_1 + \sigma_2 + \sigma_3 \\
 I_2 &= \sigma_1 \sigma_2 + \sigma_2 \sigma_3 + \sigma_1 \sigma_3 \\
 I_3 &= \sigma_1 \sigma_2 \sigma_3
 \end{aligned}
 \tag{3.25}$$

An interesting decomposition of the stress tensor is possible, if a mean normal stress is defined as follows:

$$\sigma_0 = \frac{1}{3} \sigma_{kk} = \frac{1}{3} (\sigma_{11} + \sigma_{22} + \sigma_{33})
 \tag{3.26}$$

σ_0 is also called 'hydrostatic stress state' or 'mean stress' or 'spherical stress'. Based on these definitions the stress tensor can be written as:

$$\sigma_{ij} = \sigma_0 \delta_{ij} + s_{ij}
 \tag{3.27}$$

In terms of matrix notation this means:

$$\begin{aligned}
 \begin{bmatrix} \sigma_{11} & \sigma_{12} & \sigma_{13} \\ \sigma_{21} & \sigma_{22} & \sigma_{23} \\ \sigma_{31} & \sigma_{32} & \sigma_{33} \end{bmatrix} &= \begin{bmatrix} \sigma_0 & 0 & 0 \\ 0 & \sigma_0 & 0 \\ 0 & 0 & \sigma_0 \end{bmatrix} + \begin{bmatrix} \sigma_{11} - \sigma_0 & \sigma_{12} & \sigma_{13} \\ \sigma_{21} & \sigma_{22} - \sigma_0 & \sigma_{23} \\ \sigma_{31} & \sigma_{32} & \sigma_{33} - \sigma_0 \end{bmatrix} \\
 &= \begin{bmatrix} \sigma_0 & 0 & 0 \\ 0 & \sigma_0 & 0 \\ 0 & 0 & \sigma_0 \end{bmatrix} + \begin{bmatrix} s_{11} & s_{12} & s_{13} \\ s_{21} & s_{22} & s_{23} \\ s_{31} & s_{32} & s_{33} \end{bmatrix}
 \end{aligned}
 \tag{3.28}$$

where s_{ij} is referred as deviatoric stress part. For the spherical tensor as well as for the stress deviator invariants can be defined. The main invariants for the spherical tensor are given as follows:

$$I_1^\circ = 3\sigma_0 \quad I_2^\circ = \frac{3}{2} \sigma_0^2 \quad I_3^\circ = \sigma_0^3
 \tag{3.29}$$

The corresponding basic invariants are:

$$J_1^\circ = 3\sigma_0 \quad J_2^\circ = \frac{3}{2} \sigma_0^2 \quad J_3^\circ = \sigma_0^3
 \tag{3.30}$$

For the deviatoric part the main invariants are:

$$I_1^D = s_{kk} = (\sigma_{11} - \sigma_0) + (\sigma_{22} - \sigma_0) + (\sigma_{33} - \sigma_0) = 0$$

$$\begin{aligned} I_2^D &= \frac{1}{2}(s_{ii} s_{jj} - s_{ij} s_{ji}) \\ &= (\sigma_{11} - \sigma_0)(\sigma_{22} - \sigma_0) + (\sigma_{22} - \sigma_0)(\sigma_{33} - \sigma_0) + (\sigma_{11} - \sigma_0)(\sigma_{33} - \sigma_0) - \sigma_{12}^2 - \sigma_{23}^2 - \sigma_{31}^2 \end{aligned} \quad 3.31$$

$$\begin{aligned} I_3^D &= \det(s_{ij}) \\ &= \frac{1}{3} \left(\frac{1}{2} s_{ii} s_{jj} s_{kk} + s_{ij} s_{jk} s_{ki} - \frac{3}{2} s_{ij} s_{ji} s_{kk} \right) \end{aligned}$$

The basic invariants for the deviatoric part are:

$$J_1^D = s_{kk} = 0$$

$$\begin{aligned} J_2^D &= \frac{1}{2} s_{ij} s_{ji} = \frac{1}{2} \left[(\sigma_{11} - \sigma_0)^2 + (\sigma_{22} - \sigma_0)^2 + (\sigma_{33} - \sigma_0)^2 + 2\sigma_{12}^2 + 2\sigma_{23}^2 + 2\sigma_{31}^2 \right] \\ &= \frac{1}{6} \left[(\sigma_{11} - \sigma_{22})^2 + (\sigma_{22} - \sigma_{33})^2 + (\sigma_{33} - \sigma_{11})^2 \right] + \sigma_{12}^2 + \sigma_{23}^2 + \sigma_{31}^2 \quad 3.32 \\ &= \frac{1}{6} \left[(\sigma_1 - \sigma_2)^2 + (\sigma_2 - \sigma_3)^2 + (\sigma_3 - \sigma_1)^2 \right] \end{aligned}$$

$$J_3^D = \frac{1}{3} s_{ij} s_{jk} s_{ki} = (\sigma_1 - \sigma_0) \cdot (\sigma_2 - \sigma_0) \cdot (\sigma_3 - \sigma_0)$$

Quite often stress components are defined, which are related to the octahedral plane. The octahedral plane is equally inclined to the principal stress directions (hydrostatic axis). The principal stresses act along the x_1 , x_2 and x_3 direction:

$$\sigma_{ij} = \begin{pmatrix} \sigma_1 & 0 & 0 \\ 0 & \sigma_2 & 0 \\ 0 & 0 & \sigma_3 \end{pmatrix} \quad 3.33$$

The stress vector t_j is defined by the three principal stress components σ_1 , σ_2 and σ_3 . Regarding the normal on the octahedral plane the stress vector t_j has the following cartesian components:

$$t_i^N = \sigma_{ij} n_j \quad n_j = \frac{1}{\sqrt{3}} \quad 3.34$$

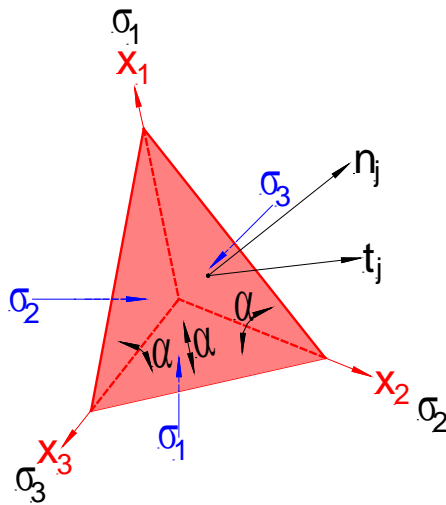

$$\alpha = \arccos\left(\frac{1}{\sqrt{3}}\right) \approx 54,7^\circ$$

$$t_j = [\sigma_1, \sigma_2, \sigma_3]$$

Fig. 3.6: Representation of octahedral stresses

The projection and summation of the components on the vektor n_j (hydrostatic axis) provides the octahedral normal stress:

$$\sigma_{OCT} = \frac{1}{\sqrt{3}} \left(\frac{\sigma_1}{\sqrt{3}} + \frac{\sigma_2}{\sqrt{3}} + \frac{\sigma_3}{\sqrt{3}} \right) = \frac{1}{3} (\sigma_1 + \sigma_2 + \sigma_3) = \sigma_0 \quad 3.35$$

The octahedral normal stress is equivalent to mean stress (Eq. 3.26). The subtraction of the octahedral normal stresses from the principal stresses leads to the deviatoric stresses:

$$\begin{aligned} s_1 &= \sigma_1 - \sigma_0 \\ s_2 &= \sigma_2 - \sigma_0 \\ s_3 &= \sigma_3 - \sigma_0 \end{aligned} \quad 3.36$$

These deviatoric stresses can also be referred to the octahedral plane and given as Cartesian components:

$$t_1^s = \frac{s_1}{\sqrt{3}} \quad t_2^s = \frac{s_2}{\sqrt{3}} \quad t_3^s = \frac{s_3}{\sqrt{3}} \quad 3.37$$

The addition of vectors leads to the octahedral shear stresses:

$$\begin{aligned}
 \tau_{OCT} &= \sqrt{(t_1)^2 + (t_2)^2 + (t_3)^2} \\
 &= \sqrt{\frac{s_1^2}{3} + \frac{s_2^2}{3} + \frac{s_3^2}{3}} \\
 &= \sqrt{\frac{1}{3}(s_1^2 + s_2^2 + s_3^2)} \\
 &= \sqrt{\frac{2}{3}J_2^D} = \sqrt{\frac{1}{3}s_{ij}s_{ij}}
 \end{aligned}
 \tag{3.38}$$

Another very popular quantity is the so-called 'von-Mises equivalent stress' σ_F . This stress value is based on a strength criterion, which relates the yield stress σ_F to the stress deviator:

$$0 = 3J_2^D - \sigma_F^2 \tag{3.39}$$

This implies that:

$$\sigma_F = \sqrt{3J_2^D} = \sqrt{\frac{3}{2}s_{ij}s_{ij}} = \frac{1}{\sqrt{2}}\sqrt{(\sigma_1 - \sigma_2)^2 + (\sigma_2 - \sigma_3)^2 + (\sigma_1 - \sigma_3)^2} \tag{3.40}$$

and

$$\tau_{OCT} = \sqrt{\frac{2}{3}\sigma_F^2} = \frac{\sqrt{2}}{3}\sigma_F \tag{3.41}$$

Principal stresses and principal stress directions:

The stress tensor as a symmetric linear operator has the characteristic, that it can be diagonalised. That means, there are three orientations (directions) perpendicular to each other in space, where the corresponding normal stresses reach extreme values (principal stresses or principal normal stresses) and the shear stresses vanish. In this case, only the trace of the tensors has non-vanishing values:

$$\sigma_{ij} = \begin{pmatrix} \sigma_1 & 0 & 0 \\ 0 & \sigma_2 & 0 \\ 0 & 0 & \sigma_3 \end{pmatrix} \tag{3.42}$$

The stress vectors on these specific surface areas coincide with the directions of the normal vectors of these surface areas. Therefore, the stress vectors have only one non-vanishing component. Thus, for the stress vector at the considered surface area it holds:

$$t_i = n_j \sigma_{ij}$$

and

$$\begin{aligned} t_1 &= n_1 \sigma_1 = l \sigma_1 \\ t_2 &= n_2 \sigma_2 = m \sigma_2 \\ t_3 &= n_3 \sigma_3 = n \sigma_3 \end{aligned} \quad 3.44$$

The normal vector $n_i = \{l, m, n\}$ describes the principal normal stress directions. For the unit vector the following holds in general:

$$\sum_{i=1}^3 n_i^2 = l^2 + m^2 + n^2 = 1 \quad 3.45$$

squaring equation 3.44 yields:

$$\begin{aligned} t_1^2 &= l^2 \sigma_1^2 \\ t_2^2 &= m^2 \sigma_2^2 \\ t_3^2 &= n^2 \sigma_3^2 \end{aligned} \quad 3.46$$

and

$$\begin{aligned} l^2 &= \frac{t_1^2}{\sigma_1^2} \\ m^2 &= \frac{t_2^2}{\sigma_2^2} \\ n^2 &= \frac{t_3^2}{\sigma_3^2} \end{aligned} \quad 3.47$$

The addition of the eq. 3.47 under consideration of eq. 3.45 gives:

$$\frac{t_1^2}{\sigma_1^2} + \frac{t_2^2}{\sigma_2^2} + \frac{t_3^2}{\sigma_3^2} = 1 \quad 3.48$$

Eq. 3.48 describes an ellipsoid, that means the values σ_1 , σ_2 and σ_3 represent the half-axes of the ellipsoid (Fig. 3.7). The surface of the ellipsoid represents all possible stress vectors. If two principal stresses are equal, a spheroid is coming up. If all principal stresses are equal (isotropic stress state) a sphere is coming up.

In geomechanics, especially in soil mechanics, descriptions on the basis of the deviatoric stress plane, see Fig. 3.8, are very common.

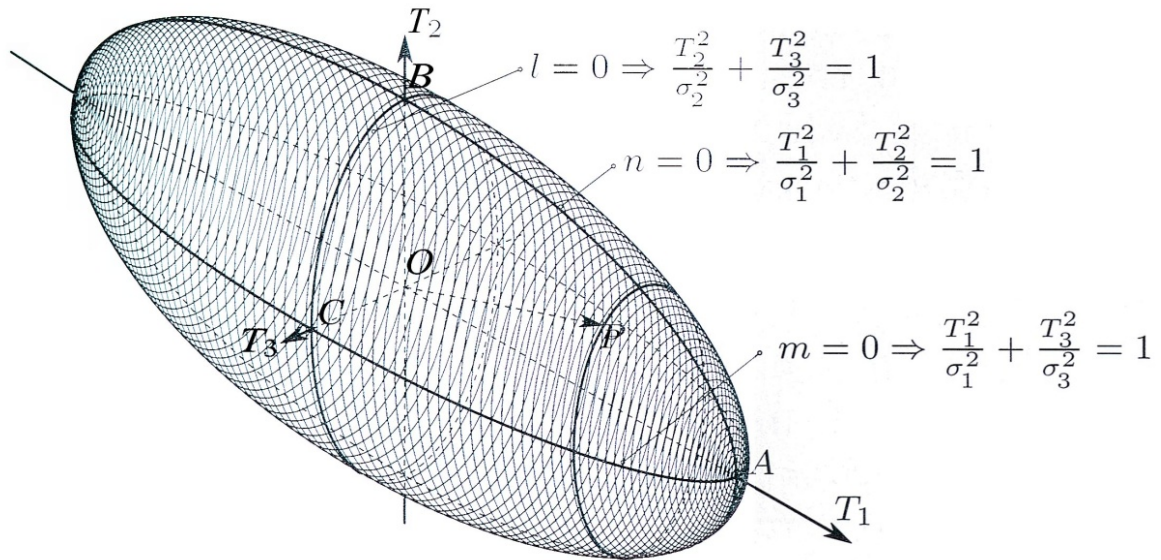

Fig. 3.7: Prinzipal stress ellipsoid

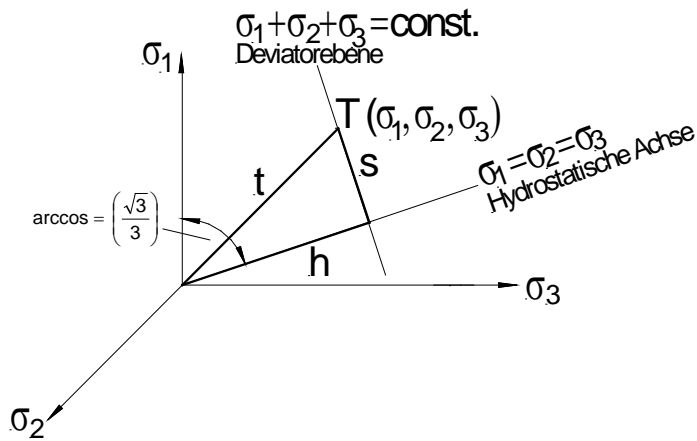
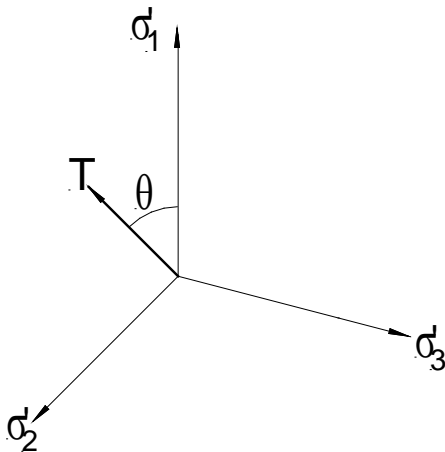

Fig. 3.8: Decomposition of the stress state into hydrostatic and deviatoric part, where the stress vector t defines the stress point T

 Fig. 3.9: Illustration of Lode angle θ in the π -plane

$$\begin{aligned}
 |h| &= \frac{\sqrt{3}}{3} (\sigma_1 + \sigma_2 + \sigma_3) = \frac{\sqrt{3}}{3} I_1 \\
 |s| &= \sqrt{s_1^2 + s_2^2 + s_3^2} = \sqrt{2J_2^D}
 \end{aligned} \tag{3.49}$$

On the deviatoric plane it holds:

$$(\sigma_1 + \sigma_2 + \sigma_3) = \text{const.} \tag{3.50}$$

The deviatoric plane through the coordinate system is also called π -plane (Fig. 3.9). It holds:

$$\begin{aligned}
 \cos(3\theta) &= \frac{3\sqrt{3}}{2} \frac{J_3^D}{(J_2^D)^{\frac{3}{2}}} \quad \text{and} \\
 \theta &= \frac{1}{3} \arccos \left[\frac{3\sqrt{3}}{2} \frac{J_3^D}{(J_2^D)^{\frac{3}{2}}} \right]
 \end{aligned} \tag{3.51}$$

In geotechnical engineering the following two modified invariants are often used: Roscoe invariants p and q as well as Lode angle θ . Thereby, it holds:

$$\begin{aligned}
 p &= \frac{1}{3} I_1, \\
 q &= \sqrt{3} J_2^D \quad \text{and} \\
 \theta &= \frac{1}{3} \arccos \left[\frac{3\sqrt{3}}{2} \frac{J_3^D}{(J_2^D)^{\frac{3}{2}}} \right].
 \end{aligned} \tag{3.52}$$

For the conventional triaxial test the following expressions can be deduced:

$$p = \frac{1}{3} (\sigma_1 + 2 \sigma_3) ,$$

$$q = \sigma_1 - \sigma_3 \text{ and}$$

3.53

$$\theta = \frac{1}{3} \arccos (3\sqrt{6} s_1 \cdot s_3^2) = 3\sqrt{6} s_1 s_2 s_3 .$$

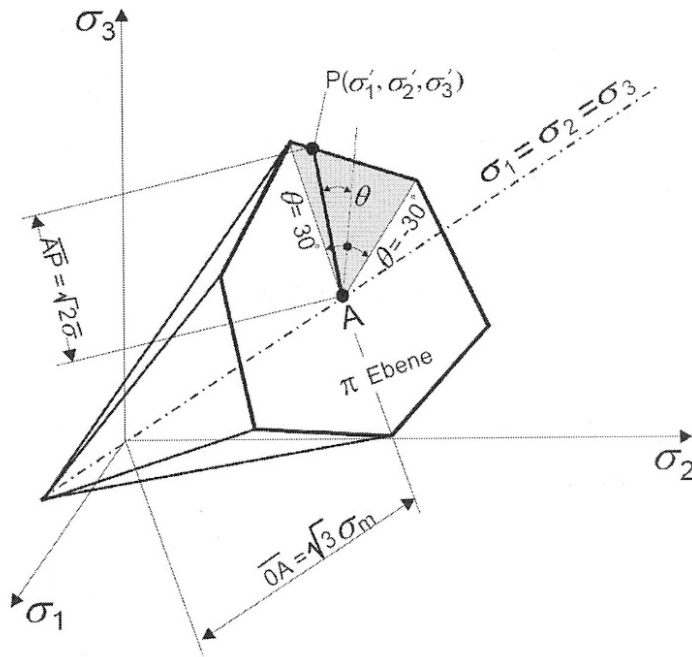

Fig. 3.10: Illustration of Lode angle in the principal stress space

4. Deformation tensor

Deformations in terms of strain (length change and angle change) can be defined in quite different ways. This is illustrated for a 1-dimensional beam under elongation, where l = final length and l_0 = initial length.

$$\varepsilon = \frac{l-l_0}{l_0} \quad \text{engineering (technical) formulation (Lagrange)}$$

$$\varepsilon = \frac{l_0-l}{l} \quad \text{engineering (technical) formulation (Euler)}$$

$$\varepsilon = \frac{1}{2} \cdot \frac{l^2 - l_0^2}{l_0^2} \quad \text{quadratic formulation (Lagrange)}$$

$$\varepsilon = \frac{1}{2} \cdot \frac{l_0^2 - l^2}{l^2} \quad \text{quadratic formulation (Euler)}$$

$$\varepsilon = \ln \frac{l}{l_0} \quad \text{logarithmic formulation}$$

All the above mentioned definitions have the following common characteristics:

- value of 0, if $l = l_0$.
- for small deformations (small strain) all above given definitions deliver nearly the same value.
- for large deformations (large strain), the above given definitions result in significant different values.

Proof of approximate equality Deformationenen for small strain:

(a) for quadratic approach:

$$\varepsilon = \frac{1}{2} \cdot \frac{l^2 - l_0^2}{l_0^2} = \frac{1}{2} \cdot \frac{(l+l_0)(l-l_0)}{l_0^2} = \frac{1}{2} \cdot \frac{(2l_0)(l-l_0)}{l_0^2} = \frac{l-l_0}{l_0}$$

(b) for logarithmic approach:

Taylor-series: $\ln(x) = \sum_{n=1}^{\infty} (-1)^{n+1} \frac{(x-1)^n}{n}$

Based on series expansion (Taylor series) the logarithmic approach yields:

$$\ln \frac{l}{l_0} = \left(\frac{l}{l_0} - 1 \right) - \frac{1}{2} \left(\frac{l}{l_0} - 1 \right)^2 + \frac{1}{3} \left(\frac{l}{l_0} - 1 \right)^3 - \frac{1}{4} \left(\frac{l}{l_0} - 1 \right)^4 + \dots$$

$$\ln \frac{l}{l_0} = \left(\frac{l-l_0}{l_0} \right) - \frac{1}{2} \left(\frac{l-l_0}{l_0} \right)^2 + \frac{1}{3} \left(\frac{l-l_0}{l_0} \right)^3 - \frac{1}{4} \left(\frac{l-l_0}{l_0} \right)^4 + \dots \approx \frac{l-l_0}{l_0}$$

Example:

stretching by 50%: engineering procedure: $\varepsilon = 0.5$
 quadratic procedure: $\varepsilon = 0.277$
 logarithmic procedure: $\varepsilon = 0.405$

stretching by 1%: engineering procedure: $\varepsilon = 0.01000$
 quadratic procedure: $\varepsilon = 0.00985$
 logarithmic procedure: $\varepsilon = 0.00995$

For the coordinates of a point at the initial and final deformed state the following inverse relations exist: $x_i = x_i(\overset{\circ}{x}_j)$ and $\overset{\circ}{x}_i = \overset{\circ}{x}_i(x_j)$.

The definition of the deformation tensor can be made in two systems:

1. In relation to the undeformed initial system
 (= Lagrange approach), that means u_i is a function of the initial coordinates

$$u_i = u_i(\overset{\circ}{x}_j) \quad 4.1$$

2. In relation to the deformed final system
 (= Euler approach), that means u_i is a function of the final coordinates.

$$u_i = \tilde{u}_i(x_j) \quad 4.2$$

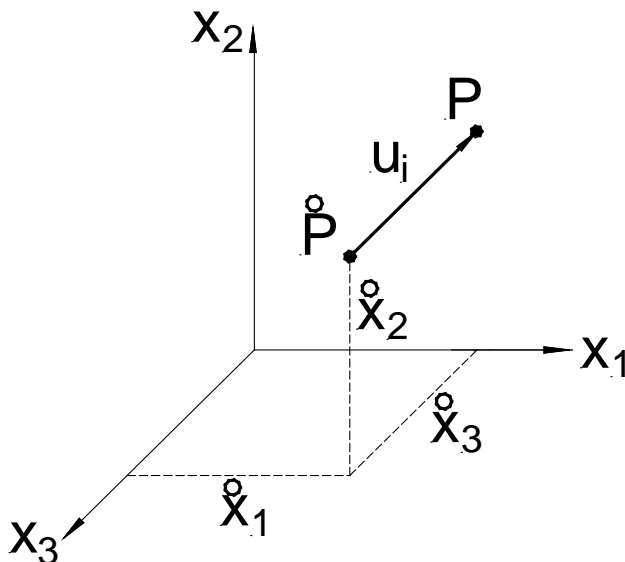

„Lagrange“

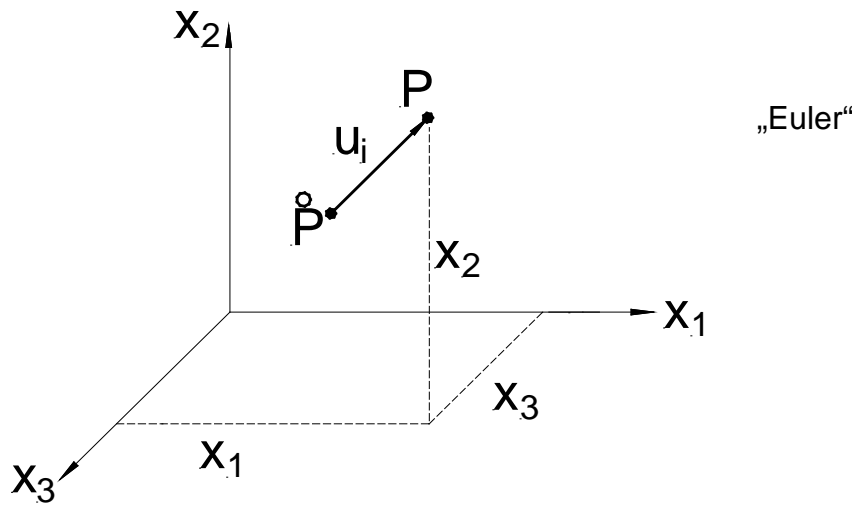

Fig. 4.1: Euler and Lagrange approaches in respect to deformations

The general definition of the deformation tensor (quadratic approach) reads as follows:

$$\overset{L}{\varepsilon}_{ij} = \frac{\partial \overset{\circ}{x}_K}{\partial \overset{\circ}{x}_i} \frac{\partial \overset{\circ}{x}_K}{\partial \overset{\circ}{x}_j} \quad (\text{Lagrange}) \quad 4.3$$

and

$$\overset{E}{\varepsilon}_{ij} = \frac{\partial \overset{\circ}{x}_K}{\partial \overset{\circ}{x}_i} \frac{\partial \overset{\circ}{x}_K}{\partial \overset{\circ}{x}_j} \quad (\text{Euler}) \quad 4.4$$

With the help of the gradient tensors (= displacement gradients) $\frac{\partial u_i}{\partial \overset{\circ}{x}_j}$ and $\frac{\partial u_i}{\partial \overset{\circ}{x}_j}$, respec-

tively, the deformation tensor can be defined as follows:
„Lagrange“:

$$\begin{aligned} x_i &= \overset{\circ}{x}_i + u_i \left(\overset{\circ}{x}_i \right) \quad \text{with} \quad \frac{\partial x_i}{\partial \overset{\circ}{x}_j} = \delta_{ij} + \frac{\partial u_i}{\partial \overset{\circ}{x}_j} \quad \text{and} \\ \overset{L}{\varepsilon}_{jK} &= \left(\delta_{ij} + \frac{\partial u_i}{\partial \overset{\circ}{x}_j} \right) \left(\delta_{ij} + \frac{\partial u_i}{\partial \overset{\circ}{x}_K} \right) \\ &= \delta_{jK} + \frac{\partial u_K}{\partial \overset{\circ}{x}_j} + \frac{\partial u_j}{\partial \overset{\circ}{x}_K} + \frac{\partial u_i}{\partial \overset{\circ}{x}_j} \frac{\partial u_i}{\partial \overset{\circ}{x}_K} \end{aligned} \quad 4.5$$

„Euler“:

$$\begin{aligned} \overset{\circ}{x}_i &= x_i - u(x_j) \quad \text{with} \quad \frac{\partial \overset{\circ}{x}_i}{\partial x_j} = \delta_{ij} - \frac{\partial u_i}{\partial x_j} \quad \text{and} \\ \varepsilon_{jK}^E &= \delta_{jK} - \frac{\partial u_i}{\partial x_K} - \frac{\partial u_K}{\partial x_j} + \frac{\partial u_i}{\partial x_j} \frac{\partial u_i}{\partial x_K} \end{aligned} \quad 4.6$$

For the Lagrangian approach the grid follows the deformations. For the Euler approach the material ‘flows’ through the stiff grid.

Besides the displacement gradient and the deformation tensor, the deformation gradient F_{ij} is of vital importance:

$$F_{ij}^L = \frac{\partial \overset{\circ}{x}_i}{\partial \overset{\circ}{x}_j} = F_{ij} \quad \text{or} \quad F_{ij}^E = \frac{\partial \overset{\circ}{x}_j}{\partial x_i} = F_{ij}^{(-1)} \quad 4.7$$

The deformation gradient is a second-rank tensor. He projects the line element vector ds_j° (initial configuration) to line element vector $d\bar{s}$ (current configuration). Thereby, the same material points are considered (Fig. 4.3). The illustration of the fundamental distinction between Euler and Lagrange approaches using numerical meshing is shown in Fig. 4.2.

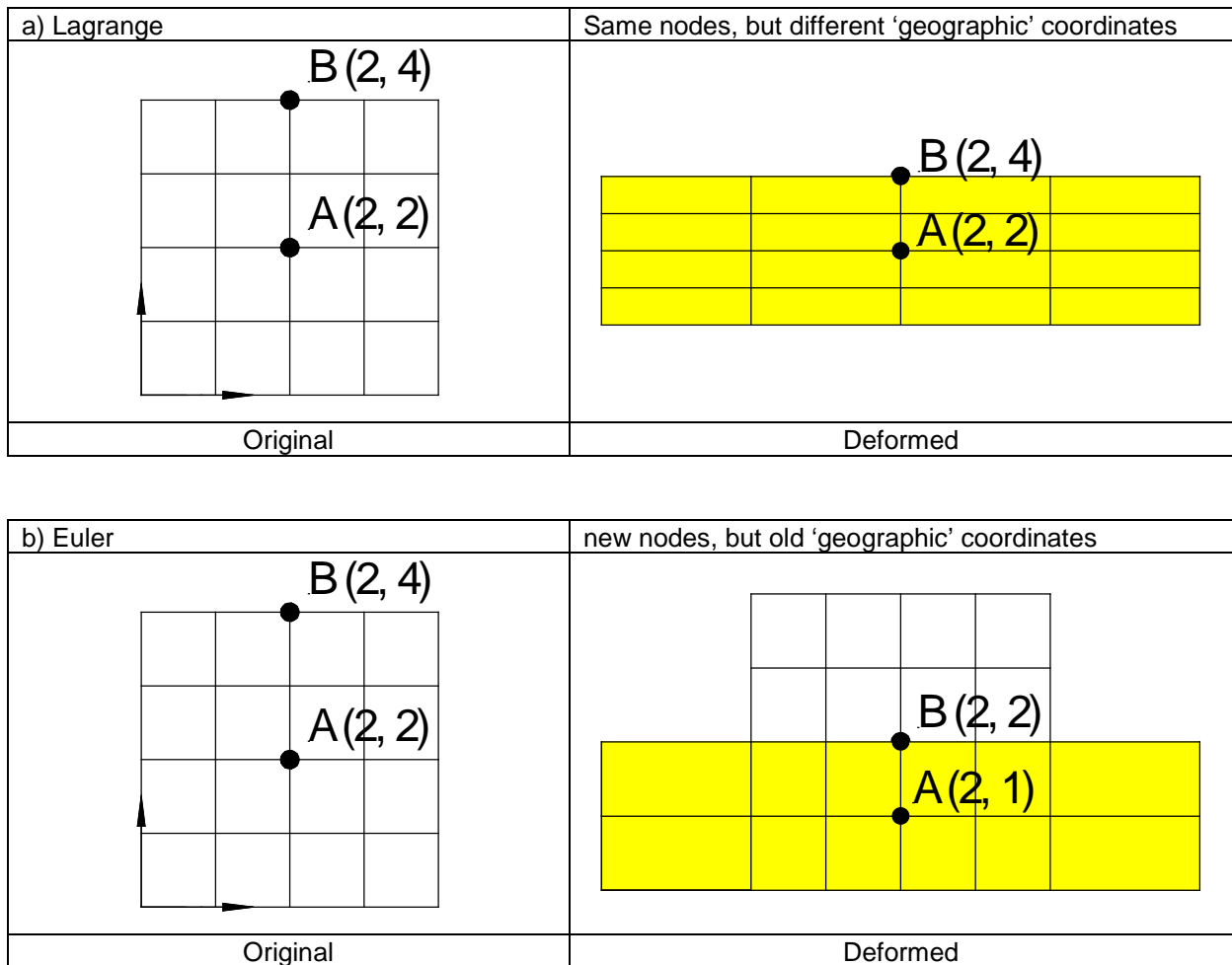

Fig. 4.1: Lagrange vs. Euler scheme

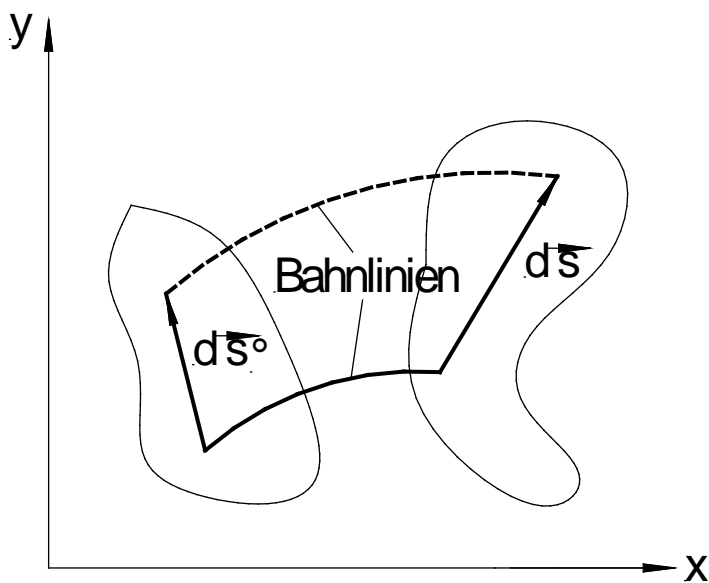

Fig. 4.3: Illustration of deformation gradient

It holds:

$$\begin{aligned} ds_i &= F_{ij} \cdot ds_j^\circ \quad \text{and} \\ ds_i^\circ &= F_{ij}^{(-1)} \cdot ds_j \end{aligned} \quad 4.8$$

From the engineering point of view the deformation gradient can be defined according to eq. 4.5 as:

$$\begin{aligned} \varepsilon_{jk}^G &= \frac{1}{2} \left(\varepsilon_{jK}^L - \delta_{jK} \right) \\ &= \frac{1}{2} \left(\frac{\partial u_j}{\partial x_K} + \frac{\partial u_K}{\partial x_j} + \frac{\partial u_i}{\partial x_j} \frac{\partial u_i}{\partial x_K} \right) \end{aligned} \quad 4.9$$

or according to eq. 4.6 as:

$$\begin{aligned} \varepsilon_{jK}^A &= \frac{1}{2} \left(\delta_{jK} - \varepsilon_{jK}^E \right) \\ &= \frac{1}{2} \left(\frac{\partial u_j}{\partial u_K} + \frac{\partial u_K}{\partial x_j} - \frac{\partial u_i}{\partial x_j} \frac{\partial u_i}{\partial x_K} \right) \end{aligned} \quad 4.10$$

Expression 4.9 is called ‘Green deformation tensor’, the expression 4.10 is called ‘Almansi deformation tensor’. In the engineering praxis the Green deformation tensor is preferred. Moreover, most often the quadratic term is neglected under the assumption, that $\frac{\partial u_i}{\partial x_j} \ll 1$. Thus, for small deformation, the distinction between Lagrangian and Eulerian approaches disappears and the simplified deformation tensor is given as:

$$\varepsilon_{ij} = \frac{1}{2} \left(\frac{\partial u_i}{\partial x_j} + \frac{\partial u_j}{\partial x_i} \right) \quad 4.11$$

The deformation tensor according to equation 4.11 can be extended to include rotations:

$$\begin{aligned} \varepsilon_{ij} &= \frac{1}{2} (u_{i,j} + u_{j,i}) + \frac{1}{2} (u_{j,i} - u_{i,j}) \\ &= \underbrace{\quad \mathbf{e}_{ij} \quad}_{\text{Deformations}} + \underbrace{\quad \mathbf{w}_{ij} \quad}_{\text{Rotations}} \end{aligned} \quad 4.12$$

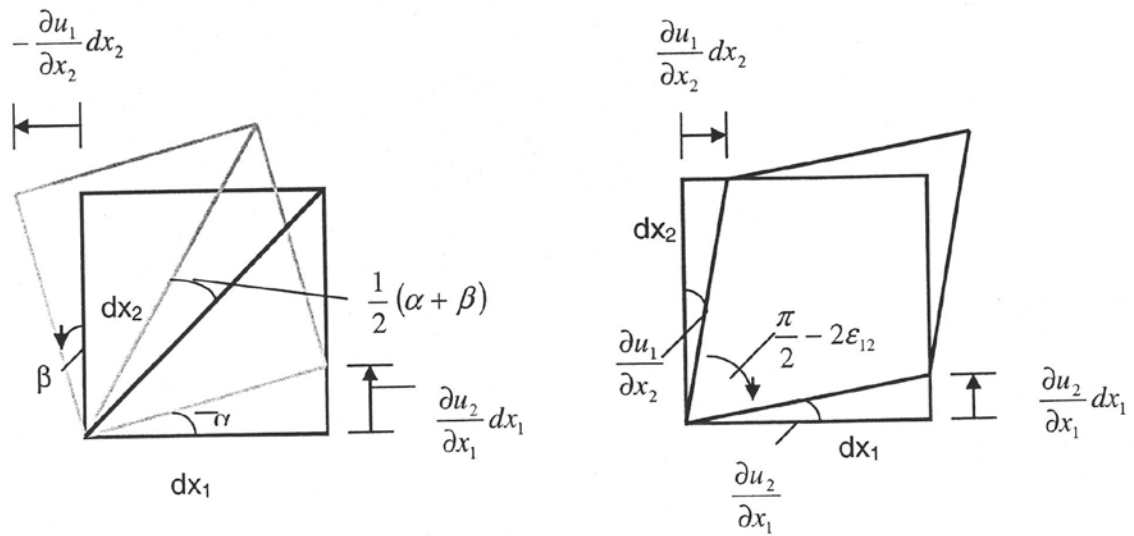

Fig.4.4: Illustration of rotation and deformation (2D)

It holds:

$$w_{ij} = \begin{pmatrix} 0 & w_{12} & w_{13} \\ w_{21} & 0 & w_{23} \\ w_{31} & w_{32} & 0 \end{pmatrix} \quad \text{with} \quad \begin{aligned} w_{12} &= -w_{21} \\ w_{13} &= -w_{31} \\ w_{23} &= -w_{32} \end{aligned}$$

and

$$e_{ij} = \begin{pmatrix} e_{11} & e_{12} & e_{13} \\ e_{21} & e_{22} & e_{23} \\ e_{31} & e_{32} & e_{33} \end{pmatrix} \quad \text{with} \quad \begin{aligned} e_{12} &= e_{21} \\ e_{13} &= e_{31} \\ e_{23} &= e_{32} \end{aligned}$$

4.13

Thus, the deformation tensor can be written as:

$$\varepsilon_{ij} = \begin{pmatrix} e_{11} & e_{12} + w_{12} & e_{13} + w_{13} \\ e_{21} + w_{21} & e_{22} & e_{23} + w_{23} \\ e_{31} + w_{31} & e_{32} + w_{32} & e_{33} \end{pmatrix}$$

4.14

with

$$e_{ij} = \frac{1}{2}(\varepsilon_{ij} + \varepsilon_{ji}) \quad \text{and} \quad w_{ij} = \frac{1}{2}(\varepsilon_{ji} - \varepsilon_{ij}) \quad \text{for } i \neq j.$$

e_{ij} is called deformation tensor, w_{ij} is called rotation tensor. It holds:

$$e_{ij} = \frac{1}{2} \kappa_{ij} \quad \text{for } i \neq j$$

4.15

Where κ_{ij} are shear strain components and e_{11} , e_{22} and e_{33} are direct strain components (elongations or shortenings).

The volumetric strain ε_v is given by the following expression:

$$\varepsilon_v = \frac{\Delta dV}{dV} = \varepsilon_{KK} = \varepsilon_{11} + \varepsilon_{22} + \varepsilon_{33} \quad 4.16$$

The mean direct strain (elongation or shortening) ε_0 is given by:

$$\varepsilon_0 = \frac{1}{3} \varepsilon_{KK} = \frac{1}{3} \varepsilon_v \quad 4.17$$

In most cases rotations are neglected and it holds:

$$\varepsilon_{ij} = \begin{pmatrix} \mathbf{e}_{11} & \mathbf{e}_{12} & \mathbf{e}_{13} \\ \mathbf{e}_{21} & \mathbf{e}_{22} & \mathbf{e}_{23} \\ \mathbf{e}_{31} & \mathbf{e}_{32} & \mathbf{e}_{33} \end{pmatrix} \quad \text{with} \quad \begin{aligned} \mathbf{e}_{12} &= \mathbf{e}_{21} \\ \mathbf{e}_{23} &= \mathbf{e}_{32} \\ \mathbf{e}_{13} &= \mathbf{e}_{31} \end{aligned} \quad 4.18$$

In complete analogy to the stress tensor invariants can be defined also for the deformation tensor, e.g.:

$$I_1 = \mathbf{e}_{11} + \mathbf{e}_{22} + \mathbf{e}_{33},$$

$$I_2 = \mathbf{e}_{11} \mathbf{e}_{22} + \mathbf{e}_{22} \mathbf{e}_{33} + \mathbf{e}_{11} \mathbf{e}_{33} \quad \text{and}$$

$$I_3 = \mathbf{e}_{11} \mathbf{e}_{22} \mathbf{e}_{33}.$$

4.19

5. Compatibility condition

From expression 5.1 the strain components can be obtained in a unique manner. Otherwise, the displacements can not be obtained in a unique manner based on given strains only. The compatibility conditions (= conditions of integrability) are necessary additional requirements to deduce displacements on the basis of given strain components by integration. The consideration of the compatibility conditions guarantees that strains lead to a 'correct' displacement field and the continuum is not disturbed. Starting point is the deformation tensor:

$$\varepsilon_{ij} = \frac{1}{2} (u_{i,j} + u_{j,i}) \quad 5.1$$

Second derivatives of equation 5.1 with corresponding index permutations give the following four expressions:

$$\begin{aligned}
\varepsilon_{ij,kl} &= \frac{1}{2}(u_{i,jkl} + u_{j,ikl}) \\
\varepsilon_{kl,ij} &= \frac{1}{2}(u_{k,lij} + u_{l,kij}) \\
\varepsilon_{ik,jl} &= \frac{1}{2}(u_{i,kjl} + u_{k,ijl}) \\
\varepsilon_{jl,ik} &= \frac{1}{2}(u_{j,lik} + u_{l,jik})
\end{aligned}
\tag{5.2}$$

Due to the fact that the sequence of differentiation is arbitrary, through addition and subtraction of the expressions 5.2 the following expression is obtained:

$$\varepsilon_{ij,kl} + \varepsilon_{kl,ij} - \varepsilon_{ik,jl} - \varepsilon_{jl,ik} = 0 \tag{5.3}$$

From expression 5.3 the 6 compatibility conditions can be deduced under the condition $\varepsilon_{ij} = \varepsilon_{ji}$ for $i \neq j$ as follows:

$$\begin{aligned}
\varepsilon_{11,22} + \varepsilon_{22,11} - 2\varepsilon_{12,12} &= 0 \\
\varepsilon_{22,33} + \varepsilon_{33,22} - 2\varepsilon_{23,23} &= 0 \\
\varepsilon_{33,11} + \varepsilon_{11,33} - 2\varepsilon_{13,13} &= 0 \\
\varepsilon_{11,23} + \varepsilon_{23,11} - \varepsilon_{13,21} - \varepsilon_{12,31} &= 0 \\
\varepsilon_{22,31} + \varepsilon_{31,22} - \varepsilon_{21,32} - \varepsilon_{23,12} &= 0 \\
\varepsilon_{33,12} + \varepsilon_{12,33} - \varepsilon_{32,13} - \varepsilon_{31,23} &= 0
\end{aligned}
\tag{5.4}$$

First equation in 5.4 can exemplarily also be written as:

$$\frac{\partial^2 \varepsilon_{xx}}{\partial y^2} + \frac{\partial^2 \varepsilon_{yy}}{\partial x^2} = 2 \frac{\partial^2 \varepsilon_{xy}}{\partial x \partial y} \tag{5.5}$$

Under plain strain conditions all strain components and derivations in respect to the third direction in space vanish, that means only equation 5.5 left over. Equation 5.5 indicates, that the second derivations of the strains and the second derivations of the angular distortions have to be in due proportion.

6. Equilibrium conditions

For any volume element inside a body the forces and moments have to be in equilibrium. Usually it is assumed, that the solid body does not rotate and therefore the sum of the moments is zero by default. According to Fig. 6.1 the following yields:

$$\sum F_x = 0:$$

$$\begin{aligned} &= \left(\sigma_x + \frac{\partial \sigma_x}{\partial x} dx \right) dy dz - \sigma_x dy dz + \left(\tau_{yx} + \frac{\partial \tau_{yx}}{\partial y} dy \right) dz dx \\ &\quad - \tau_{yx} dz dx + \left(\tau_{zx} + \frac{\partial \tau_{zx}}{\partial z} dz \right) dx dy \\ &\quad - \tau_{zx} dx dy + F_x dx dy dz \end{aligned} \quad 6.1$$

$$\sum F_y = 0:$$

$$\begin{aligned} &= \left(\sigma_y + \frac{\partial \sigma_y}{\partial y} dy \right) dx dz - \sigma_y dx dz + \left(\tau_{zy} + \frac{\partial \tau_{zy}}{\partial z} dz \right) dx dy \\ &\quad - \tau_{xy} dz dy + \left(\tau_{xy} + \frac{\partial \tau_{xy}}{\partial x} dx \right) dy dz \\ &\quad - \tau_{zy} dx dy + F_y dx dy dz \end{aligned} \quad 6.2$$

$$\sum F_z = 0:$$

$$\begin{aligned} &= \left(\sigma_z + \frac{\partial \sigma_z}{\partial z} dz \right) dx dy - \sigma_z dx dy + \left(\tau_{zy} + \frac{\partial \tau_{zy}}{\partial y} dy \right) dx dz \\ &\quad - \tau_{zy} dx dz + \left(\tau_{xz} + \frac{\partial \tau_{xz}}{\partial x} dx \right) dy dz \\ &\quad - \tau_{xz} dy dz + F_z dx dy dz \end{aligned} \quad 6.3$$

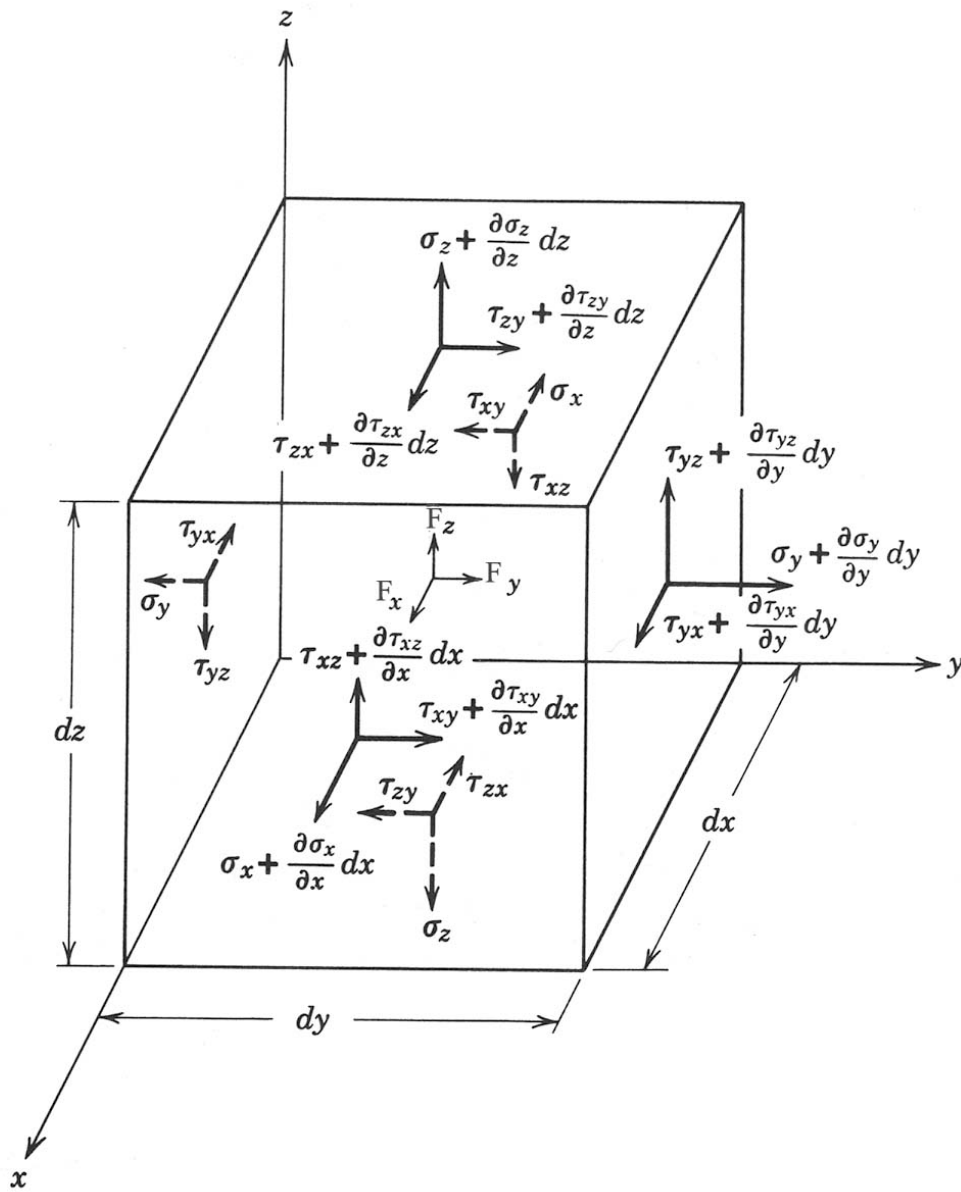

Fig. 6.1: Force equilibrium at volume element (F_i : volume forces)

Eq. 6.1 to 6.3 can be simplified in the following way:

$$\frac{\partial \sigma_x}{\partial x} + \frac{\partial \tau_{yx}}{\partial y} + \frac{\partial \tau_{zx}}{\partial z} + F_x = 0$$

$$\frac{\partial \tau_{xy}}{\partial x} + \frac{\partial \sigma_y}{\partial y} + \frac{\partial \tau_{zy}}{\partial z} + F_y = 0$$

$$\frac{\partial \tau_{xz}}{\partial x} + \frac{\partial \tau_{yz}}{\partial y} + \frac{\partial \sigma_z}{\partial z} + F_z = 0$$

6.4