

Rock bolting

Authors: Prof. Dr. habil. Heinz Konietzky (TU Bergakademie Freiberg, Geotechnical Institute)

1	Introduction.....	2
2	Physical mechanisms	2
3	Bolt types / classification	4
4	Popular bolt types.....	4
4.1	Split set anchor.....	4
4.2	Swellex-anchor	5
4.3	Expansion shell anchor	7
4.4	GRP-bolts	8
4.5	SN-anchor	8
4.6	Energy-absorbing anchors	10
4.7	Self-drilling anchor systems.....	13
4.8	Cable bolts	13
5	General behaviour	14
6	Anchor testing and monitoring.....	17
7	Design methodologies	23
8	Anchor installation	25
9	Dimensioning.....	25
10	Literature.....	34

1 Introduction

Within this chapter the term 'rock bolting' is used in a more general way including bolts, cables, dowels and nails. All of them are either stiff or flexible bar-like elongated parts mainly made of steel or synthetics, which are placed in boreholes to stabilize the rock mass. Depending on rock mass conditions, stress state and task (target), quite different types of bolts and different bolting schemes are applied.

2 Physical mechanisms

In general bolting can have the following effects (e.g. Hausdorf 2006, Hossein 2006, Li, 2017):

- **Suspension:** Dead weight of overlying strata is carried by anchor, which is fixed in strong layer above (Fig. 2.1).



Fig. 2.1: Suspension mechanism

- **Beam building:** Several layers are clamped together, so that a thicker beam is built with higher moment of inertia, stiffness and strength, respectively (Fig. 2.2).

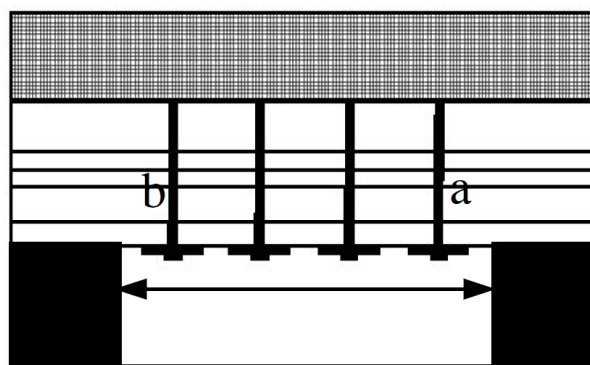

Fig. 2.2: Beam building mechanism

- **Wedging (keying) effect:** Several blocks or rock wedges are held together by anchors, so that friction and interlocking can develop (Fig. 2.3).



Fig. 2.3: Wedging effect mechanism

- **Arching effect:** Bolts create an arch around the opening as stabilizing element (Fig. 2.4).

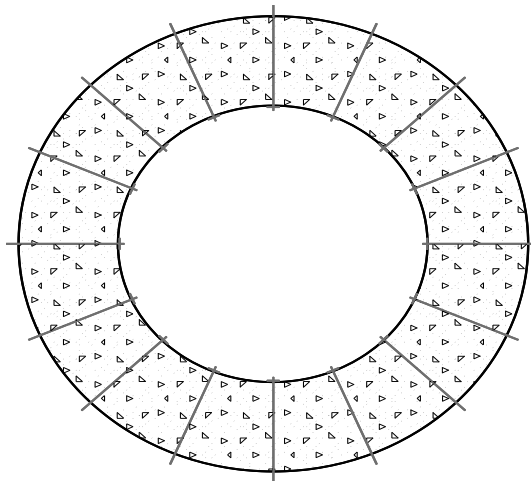

Fig. 2.44: Arching effect mechanism

3 Bolt types / classification

In a wider context bolts can be subdivided into the following groups:

- Anchors working by frictional contact along the whole anchor length (e.g. split set anchor or swellex anchor)
- Fully grouted anchors (whole anchor length is connected to the rock mass via cement or resin)
- Anchors, which are fixed only over a certain part of the anchor length (e.g. expansion shell anchors or anchors with slit, wedge or cone mechanism)
- Self-drilling anchor systems (hollow self drilling anchor for grouting or with expansion shell)
- Energy-absorbing anchors (anchors which can absorb energy from moving rock mass due to controlled lengthening)
- Cable bolts with one or several steel or geosynthetic fibres connected to the rock mass via cement or resin

4 Popular bolt types

4.1 Split set anchor

Split set anchors consists of two parts: a tube and a bearing plate (Fig. 4.1 and 4.2). The tube is driven into a slightly smaller borehole using percussion drilling equipment. As the tube slides into place, its full length slot narrows, the tube exerts radial pressure against the rock over its full contact length. Immediate support is given. Load bearing capacity is between about 50 kN to 100 kN. Split set anchors are cheap and easy and fast in use.



Fig. 4.1: Split set anchor (Int. Rollforms, company material)

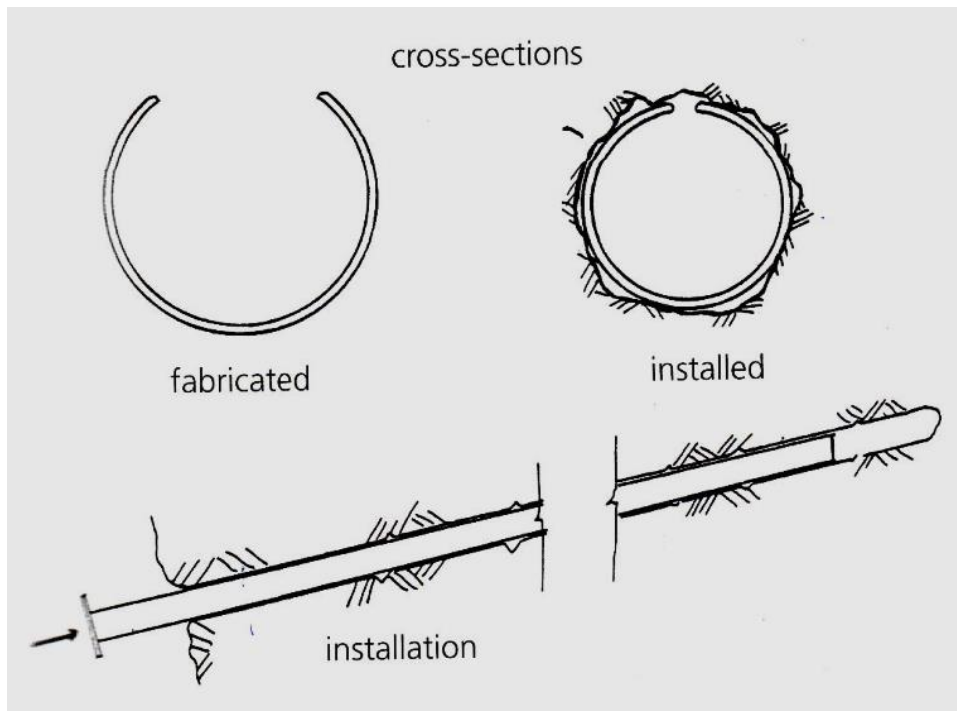

Fig. 4.2: Split set anchor (Minova, company material)

4.2 Swellex-anchor

Swellex anchors consist of several segments, which can be connected to reach the desired length of up to several meters (Fig. 4.3). The anchor is expanded by hydraulic pressure (app. 30 MPa), which creates a tight frictional contact of the anchor to the rock mass (Fig. 4.4 and 4.5). Swellex anchors offer immediate support (no time delay). Bearing capacity up to 200 kN.



Fig. 4.3: Cross section of inflatable Swellex-anchors (Atlas Copco, company material)

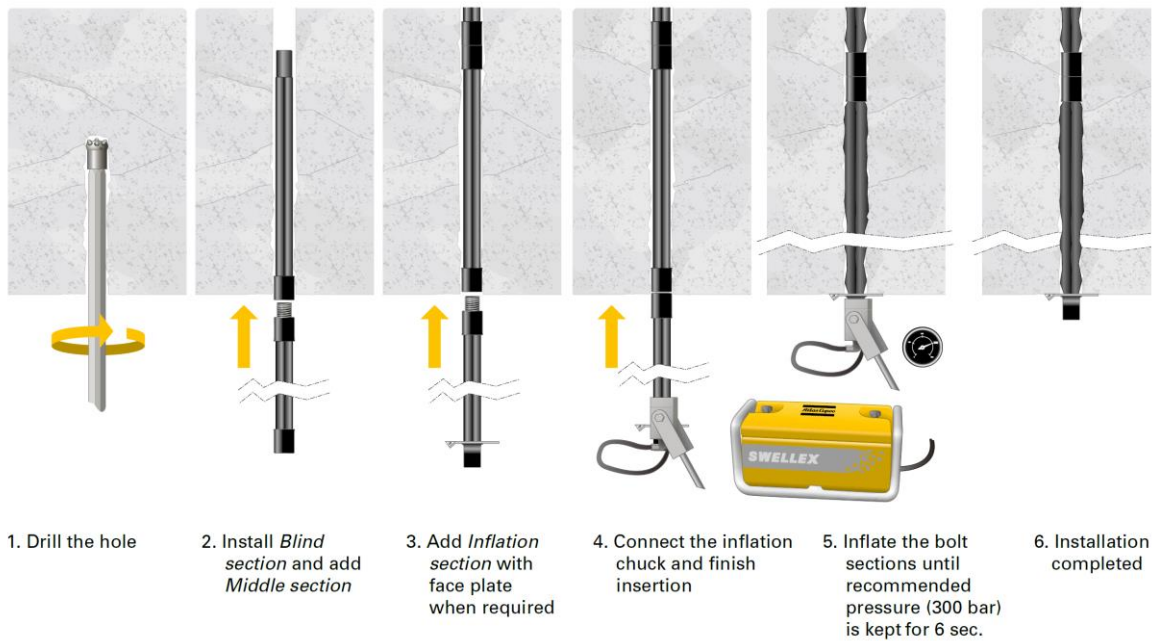

Fig. 4.4: Installation procedure for Swellex-anchors (Atlas Copco, company material)

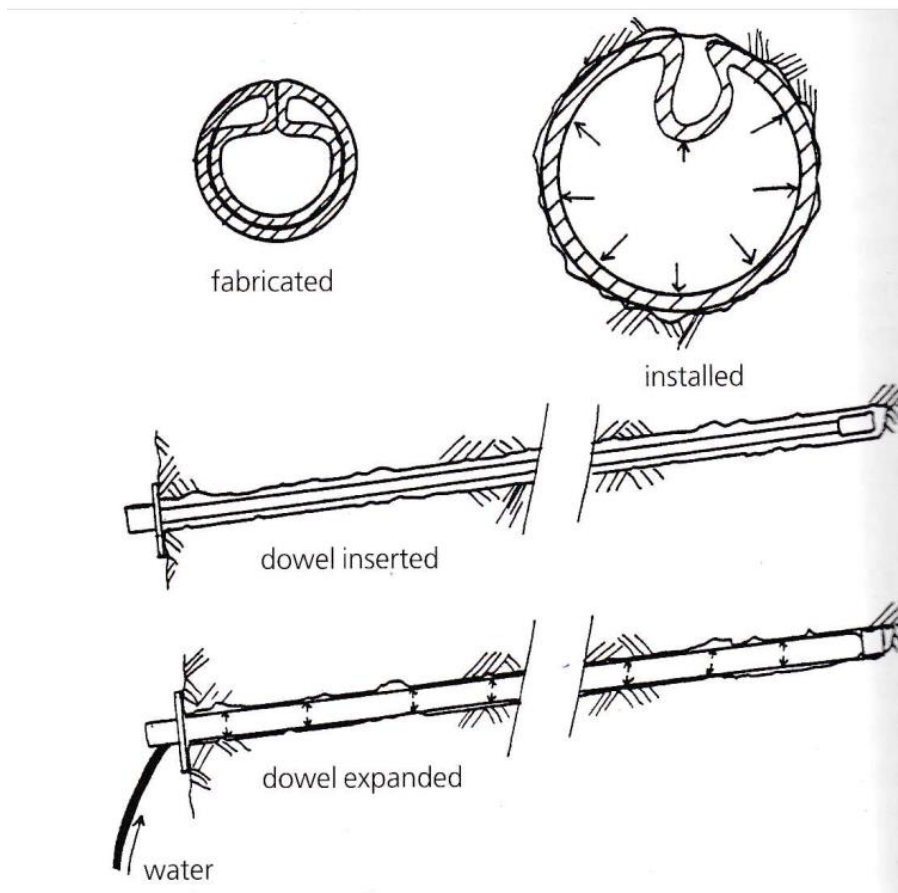

Fig. 4.5: Working principle of Swellex-anchors (Minova, company material)

4.3 Expansion shell anchor

Expansion shell anchors consist of anchor shaft, anchor plate, anchor nut and expansion shell (Fig. 4.6 and 4.7). By rotating the anchor nut the shell expands and fixes the anchor to the rock mass. This anchor type allows to produce a pre-tension, which can be adjusted by applying a torque spanner. Typical length of such anchors is 1 m to 5 m. Load bearing capacity from 100 kN to about 500 kN. Main application is systematic anchoring in mining and tunnelling.

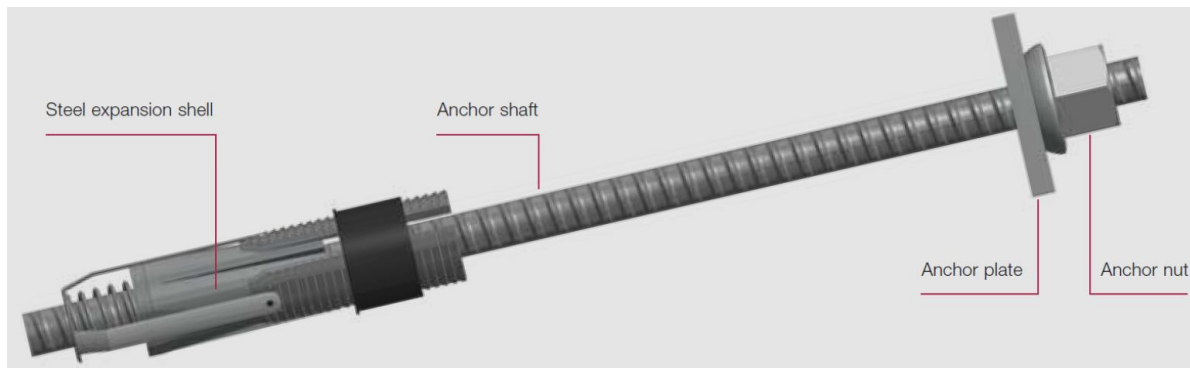

Fig. 4.6: Expansion shell anchor (DYWIDAG, company material)

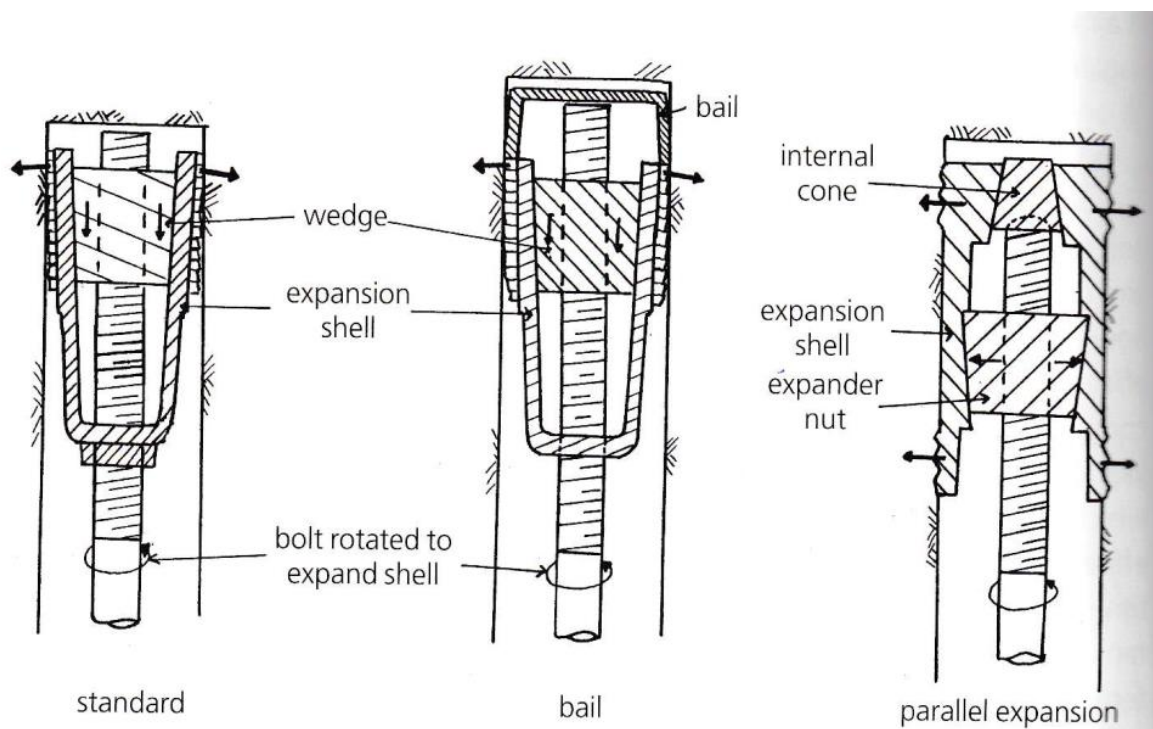

Fig. 4.7: Expansion shell anchor (Minova, company material)

4.4 GRP-bolts

GRP-bolts (Glass Fibre Reinforced Plastics) are used as an alternative to conventional steel anchors (Fig 4.8). The advantages are low weight, easy to cut by excavators, high tensile bearing capacity (tensile strength of up to over 1 GPa) and enhanced corrosion resistance. They are also offered as self-drilling anchors or GRP cable bolts.

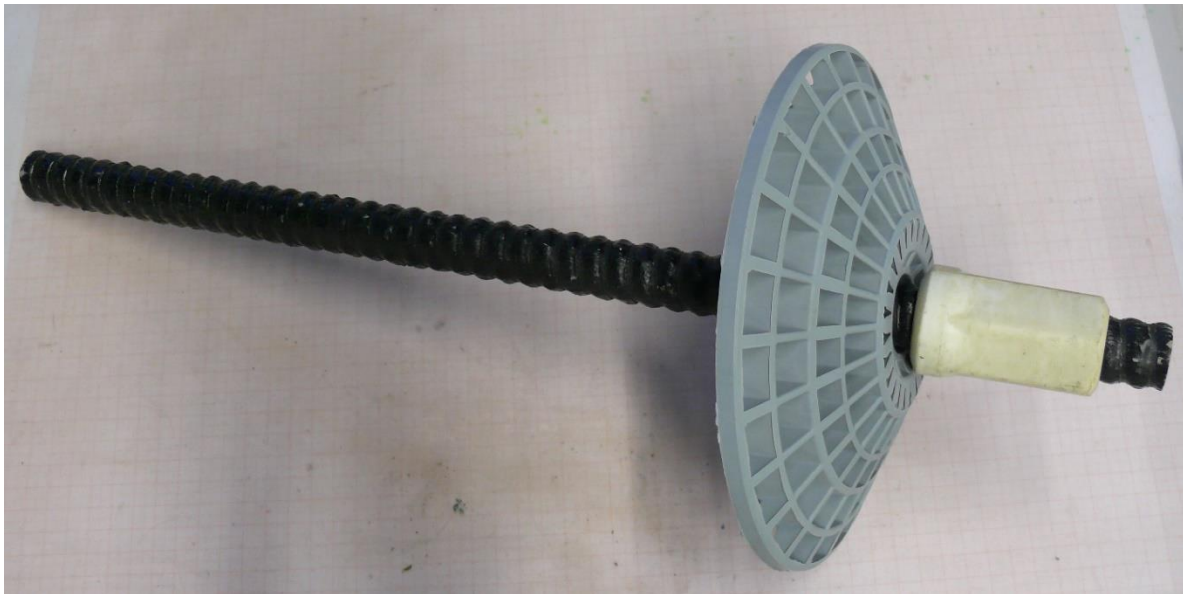

Fig. 4.8: GRP-anchor

4.5 SN-anchor

SN-anchors (mortar embedded concrete reinforcement steel anchors) consist of rock bolt shaft, plate and nut (Fig. 4.9). Special mortar along the whole rock bolt shaft creates cohesive bonding between rock mass and rock bolt shaft. Main application is systematic bolting in mining and civil engineering, especially in fractured and soft rocks. Load bearing capacity varies between about 100 kN and up to 2000 kN.



Fig. 4.9: SN-anchor (DYWIDAG, company material)

Fig. 4.10 illustrates a rockbolt with resin (two components) or cement capsules. During the installation the capsules will be destroyed, resin or cement fills the space between the anchor rod and the borehole wall and creates the tight fixation. Fig. 4.11 shows the gel time (setting time) of resins. The setting time has be reached before the bolt can be tensioned.

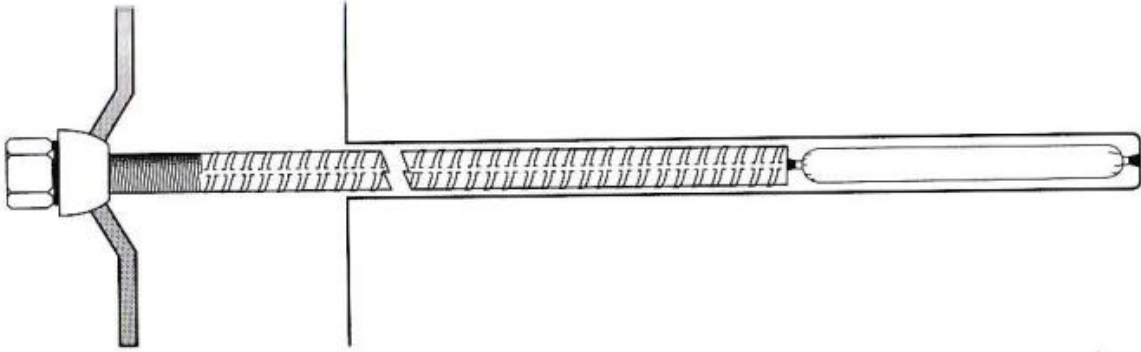

Fig. 4.10: Anchor with resin or cement cartridge and capsules, respectively (Minova, company material)

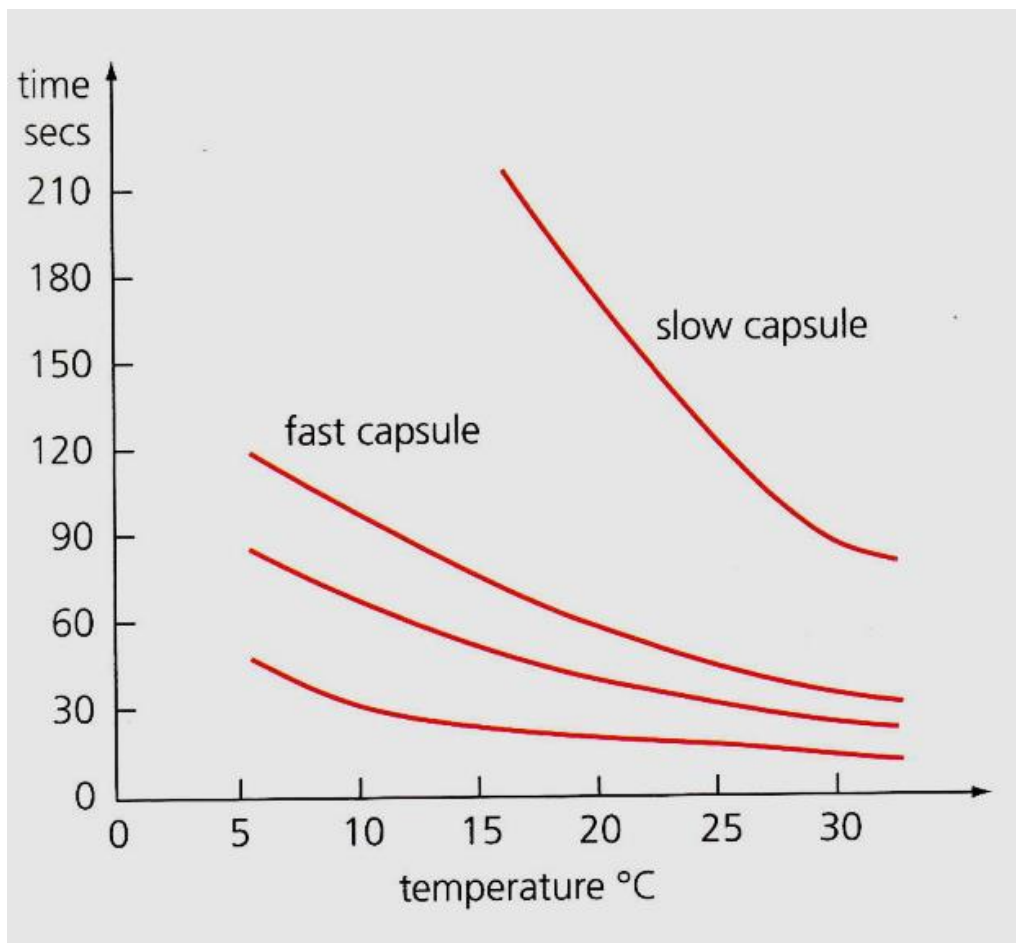

Fig. 4.11: Gel time of resin (Minova, company material)

4.6 Energy-absorbing anchors

Such anchors are designed for yielding (squeezing) rock mass or rock burst prone environment. A special steel sliding mechanism in combination with special energy absorbers and monitoring elements allows controlled rock mass deformation and energy release by keeping the rock mass stable. Meanwhile the absorbing energy of classical anchors (e.g. rebars) is in the order of just a few kJ (1-5 kJ), energy absorbing anchors can absorb between 25 kJ and 50 kJ. The high amount of absorbing energy is possible to the high strength (about 100 kN to 300 kN) and the large strain (displacements of up to 500 mm; see exemplary also Fig. 4.12). Fig. 4.13 to 4.16 illustrate some of the developed energy-absorbing anchors, which play an increasing role due to mining and tunnelling at great depths.

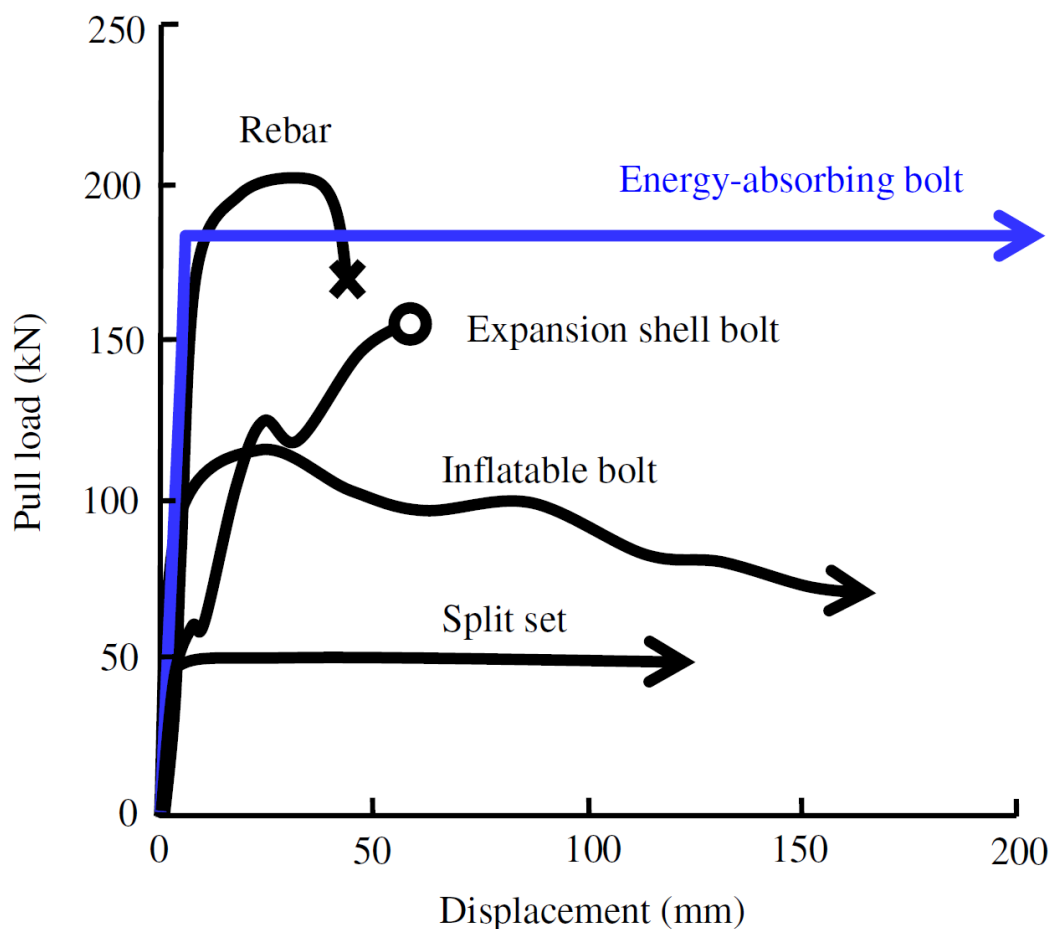

Fig. 4.12: Stress-deformation curves for energy-absorbing anchors in comparison to classical anchors (Li et al., 2014)

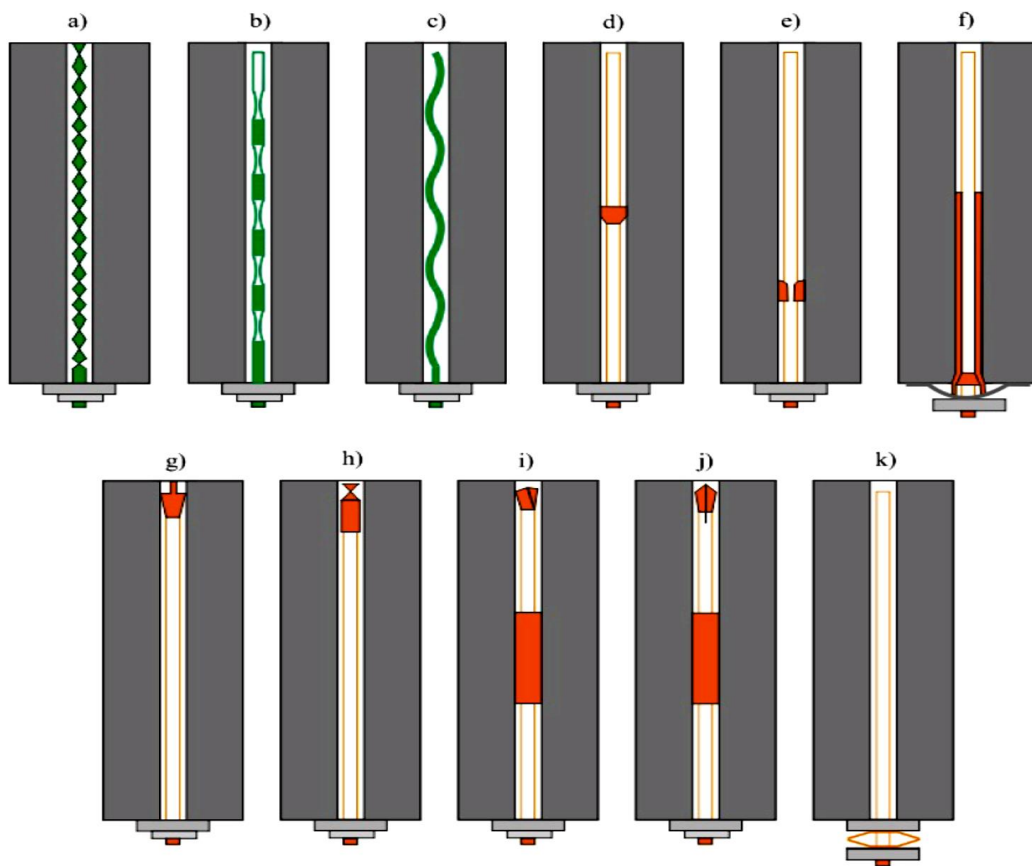

Fig. 4.13: Different types of energy-absorbing anchors (Skrzypkowski, 2018)

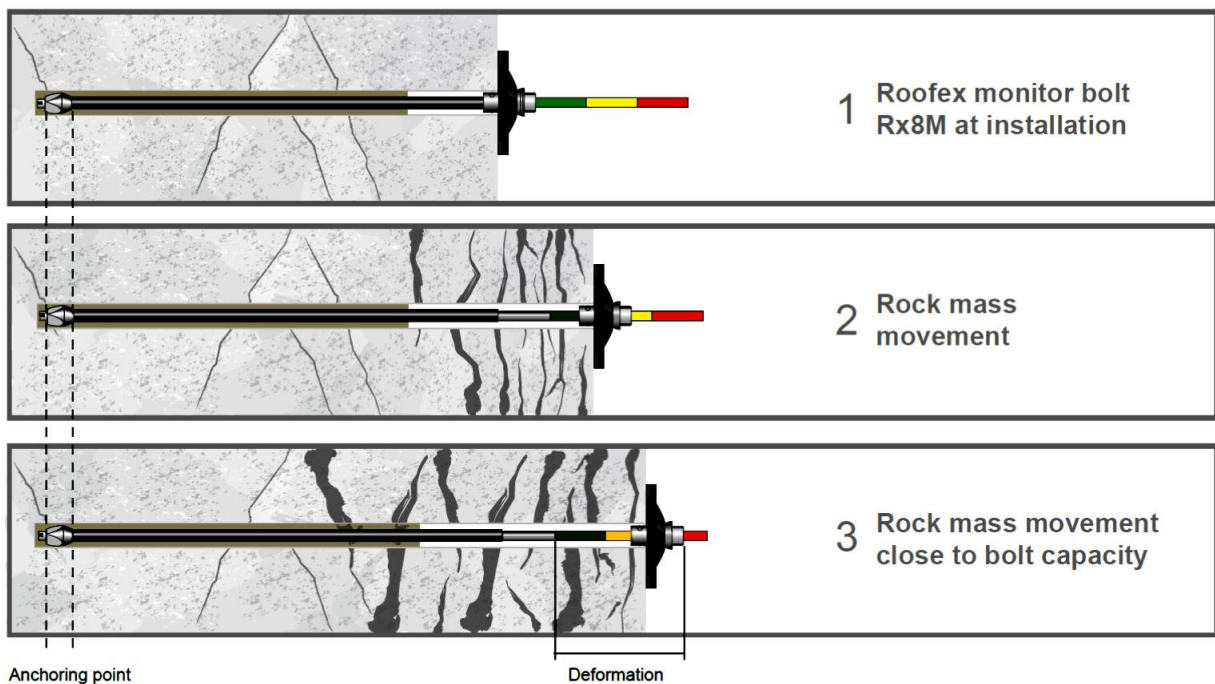

Fig. 4.14: Roofex monitor bolt (Atlas Copco, company material)

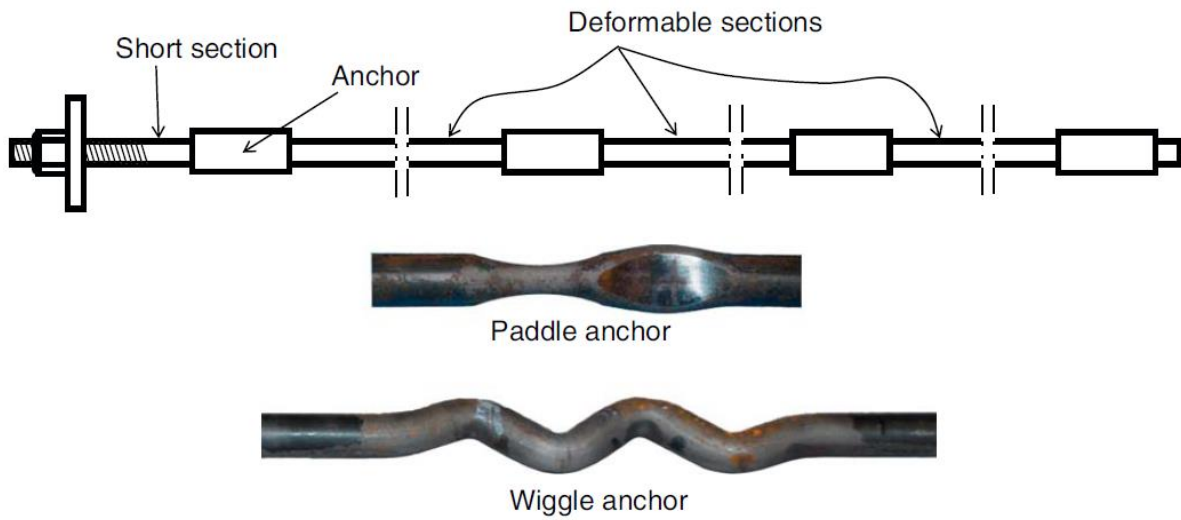

Fig. 4.15: Example for energy-absorbing anchor (Li 2010)

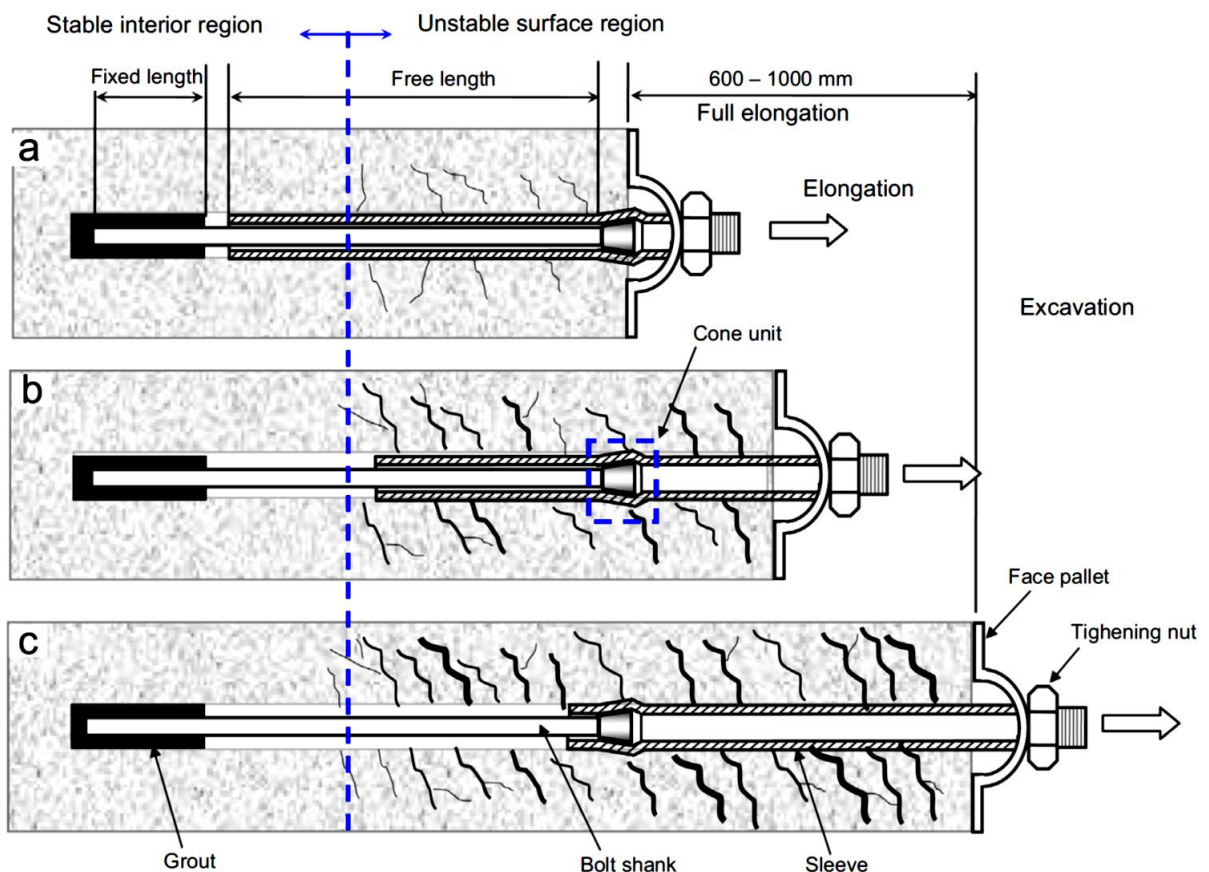

Fig. 4.16: Example for energy-absorbing anchor (He et al., 2014)

4.7 Self-drilling anchor systems

Self-drilling anchors are characterized by the fact, that the drill rod itself acts as part of the anchor and the drill bit is lost. Such systems can work with frictional elements (e.g. expansion shells), but in most cases the openings at the drill bit are used for secondary injection of grout to fix the anchor (Fig. 4.17).



Fig. 4.17: Components of self-drilling bolts (company material ACEdrills)

4.8 Cable bolts

Cable bolts are produced with flexible lengths up to several tens of meters and different numbers of steel fibres and diameters (Fig. 4.18). Such anchors are fixed via cement or resin cartridges, cement grout or injection resin. The big advantage of such bolt systems is, that they can be displaced in limited space. They are characterized by high load bearing capacity and the possibility to apply pre-tension.

Cable bolt, plain version



Cable bolt, with bulbs



DYWIDAG Strand Thread Anchors



Fig. 4.18: Typical cable bolts (DYWIDAG company material)

5 General behaviour

Typical load-displacement behaviour and load bearing capacity for different anchors are shown in Fig. 5.1. It is shown, that resin and cement grouted anchors have the highest failure load, but behave quite stiff (low failure deformation). On the other hand, anchors based on frictional contact, like Swellex or split set anchors, have lower failure deformation but allow large deformation.

The overall behaviour of anchors is determined (depending on type of anchor) by several components:

- Stiffness and non-linear stress-strain response, respectively, of anchor bar or cable itself
- Stiffness and non-linear stress-strain response, respectively, of grout (cement, mortar, resin etc.)
- Stiffness and strength at the contact between rock mass and anchor
- Stress-strain behaviour and strength of rock mass itself
- Value of pre-tension
- Diameter and length of anchor itself
- Length of fixation
- Distance between anchors

Depending on the geomechanical situation bolts have to withstand tensile and / or shear loading as illustrated in Fig. 5.2.

For fully or partially bonded anchors the bonding material incl. curing time has important influence on force-displacement behaviour and maximum pull-out force as documented exemplarily by Fig. 5.3 and 5.4.

Lifetime of metal anchors is heavily dependent on corrosion. To extend lifetime and functionality, especially in aggressive and wet environment, corrosion protection (special anti-corrosion tubes, epoxy coating, galvanizing etc.) is applied. Fig. 5.5 shows a so called "Permanent Anchor" with steel bar surrounded by an internal cement grout encapsulated within a corrugated plastic duct.

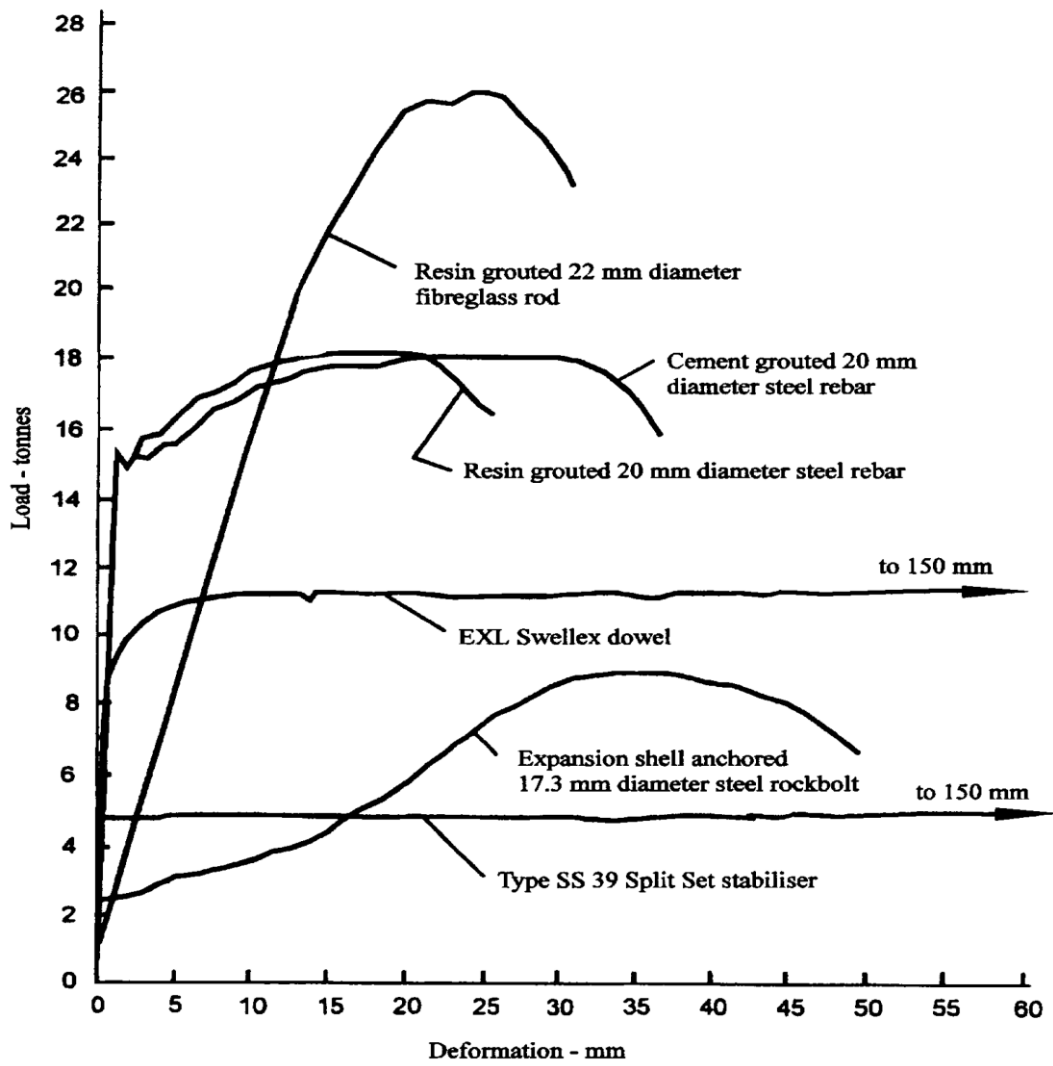

Fig. 5.1: Typical behaviour of different bolt systems (Stilleborg 1994)

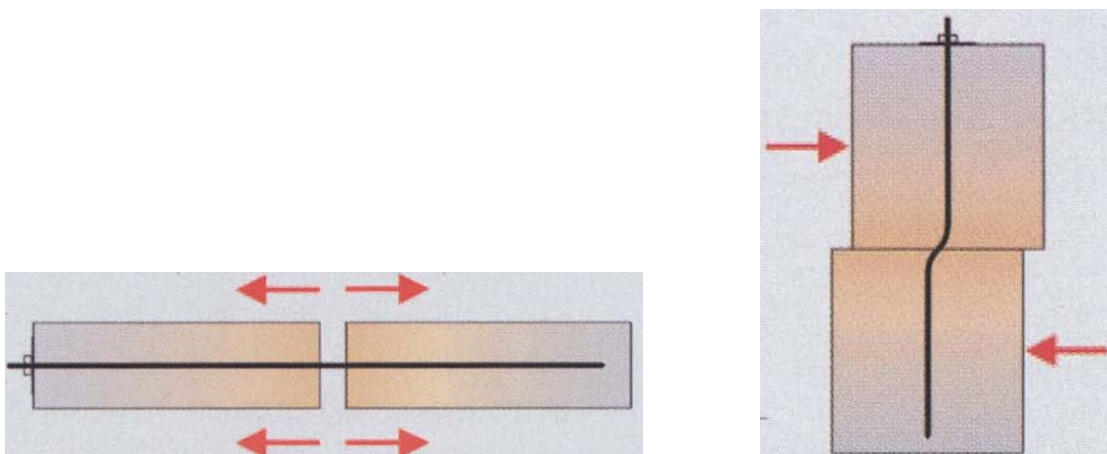

Fig. 5.2: Illustration of tensile (left) and shear (right) loading

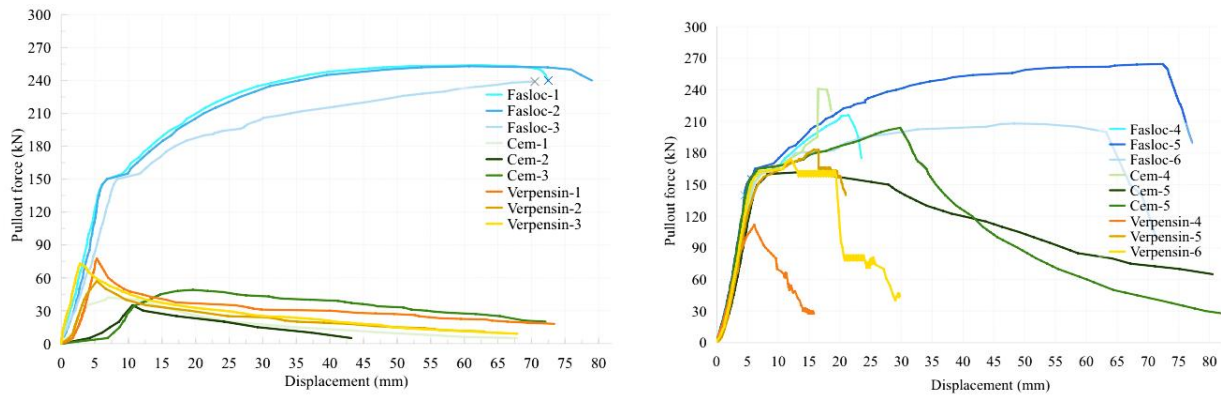

Fig. 5.3: Results from fully grouted pull-out tests after 24 hours (left) and 28 days (right); bond types: Fasloc (resin), Verpensis (organic mineral glue) and Cem (portland cement), (Malkowski et al., 2023)

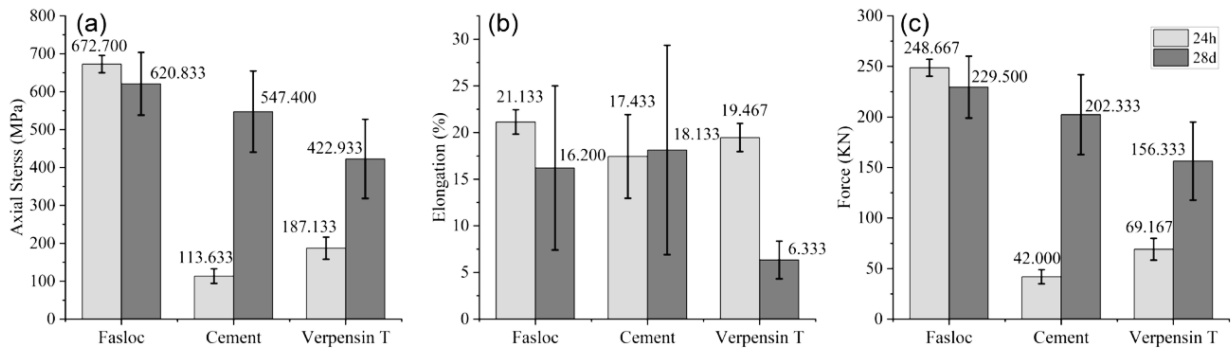

Fig. 5.4: Maximum pull-out force for fully grouted anchors after 24 hours and 28 days; bond types: Fasloc (resin), Verpensis (organic mineral glue) and Cem (portland cement), (Malkowski et al., 2023)



Fig. 5.5: Permanent anchor with bar, grout and corrugated plastic duct (DYWIDAG, company material)

6 Anchor testing and monitoring

Load capacity of anchors can be tested in the field or in the laboratory by pull-out-tests (tension loading) or shear tests (shear loading). Fig. 6.1 to 4.5 show the laboratory test set-up to conduct pull-out tests, shear tests or combined tensile-shear tests. Fig. 6.5 shows an in-situ pull-out test. Pull-out tests are also performed in the field to verify that the installed anchors fulfil the requirements according to the geotechnical design. Rock bolt tests should be performed according to standards like DIN-21521, ISRM recommendations for rock bolt testing or ASTM D 4435.



Fig. 6.1.: Direct tension test of bolt (Frühwirt 2011)

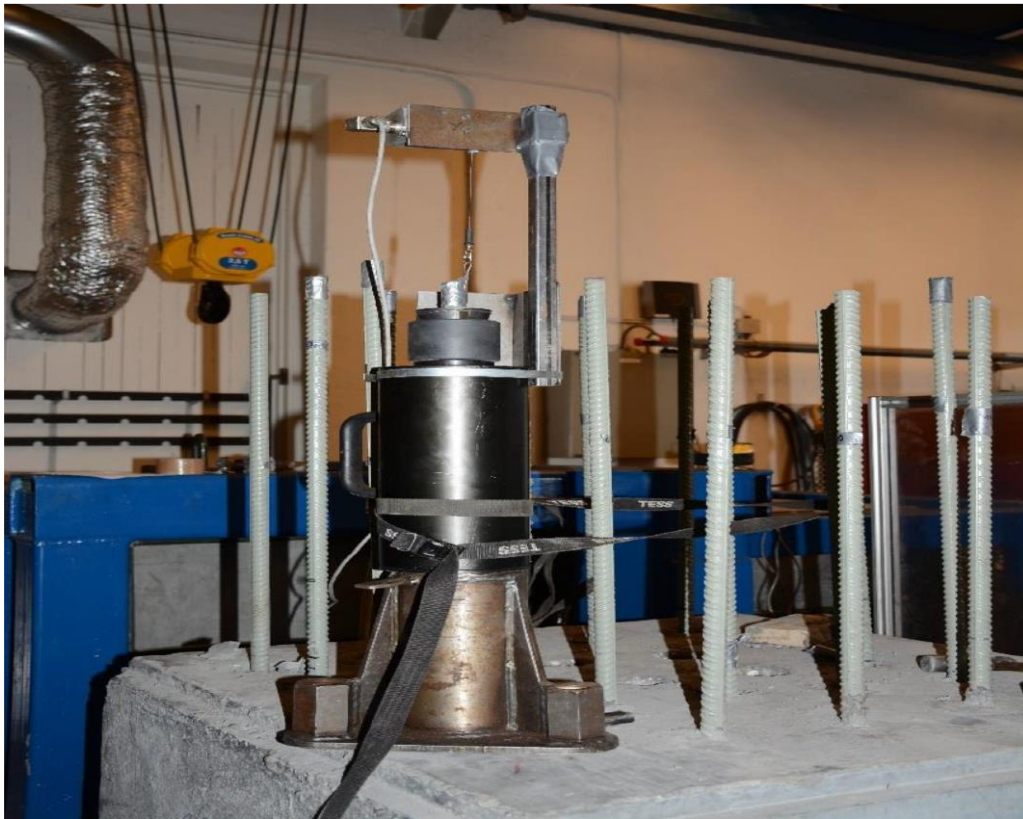

Fig. 6.2: Lab test set-up for pull-out-test (Kristjansson 2014)

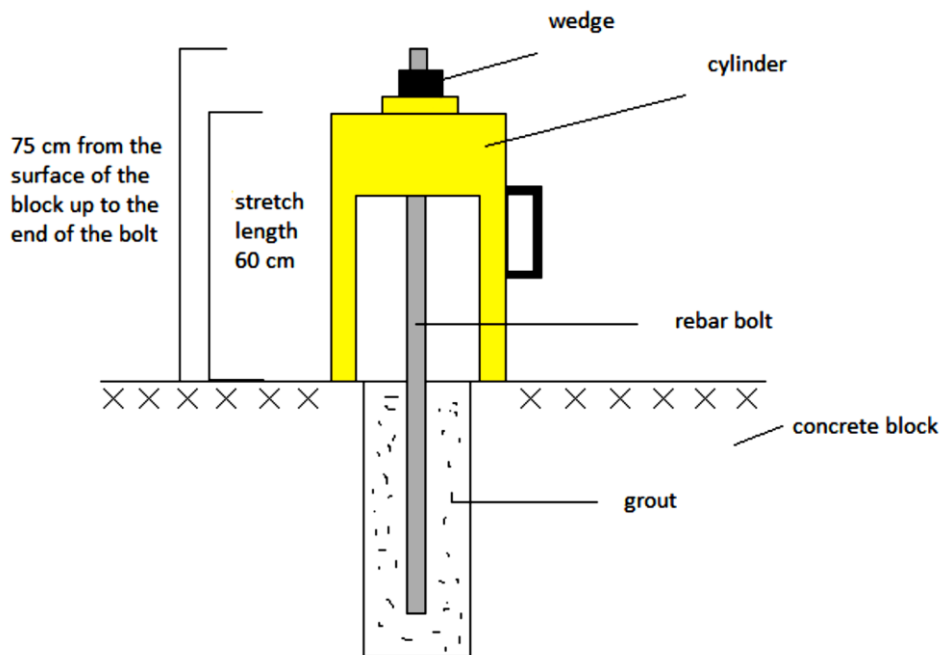

Fig. 6.3: Sketch for principal set-up of anchor pull-out-tests (Kristjansson 2014)

The actual workload as well as the desired pre-tension of the anchor can be monitored by different systems (Fig. 6.6 to 6.10). Popular are simple systems like deformable washers with defined force-deformation characteristics for visual inspection. A more precise system was developed by Frühwirt (2008), which is based on DMS fixed at the anchors. By precise measuring the elongation of the anchor bar, the load can be deduced. Such a system is also able to measure dynamic induced anchor loads like generated during blasting. Fig. 6.10 shows an anchor load cell based on a hydraulic pressure chamber with a connected manometer or with electronic transducer.

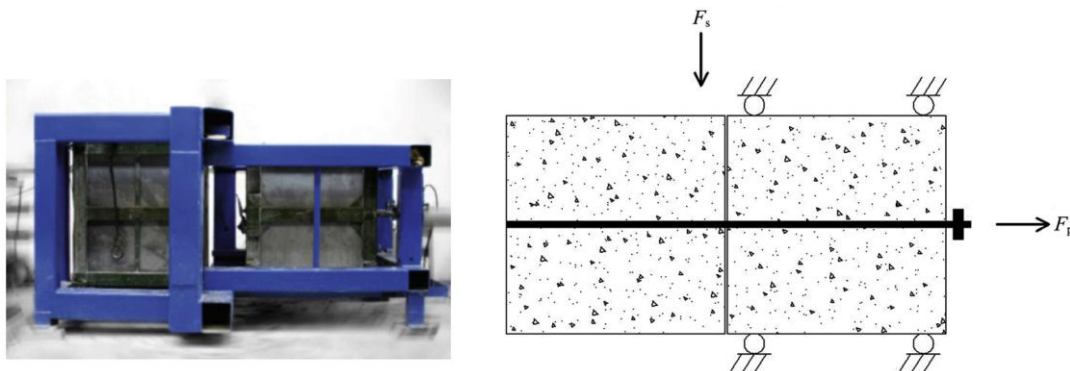

Fig. 6.4: Lab test device for combined shear and tension loading on rock bolt (Chen 2014)



Fig. 6.5: Anchor pull-out test in the field

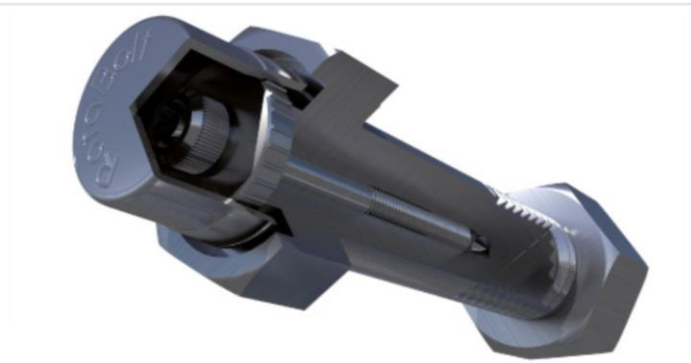

Fig. 6.6: Load tension monitoring systems for anchors (Bertfelt, company material)

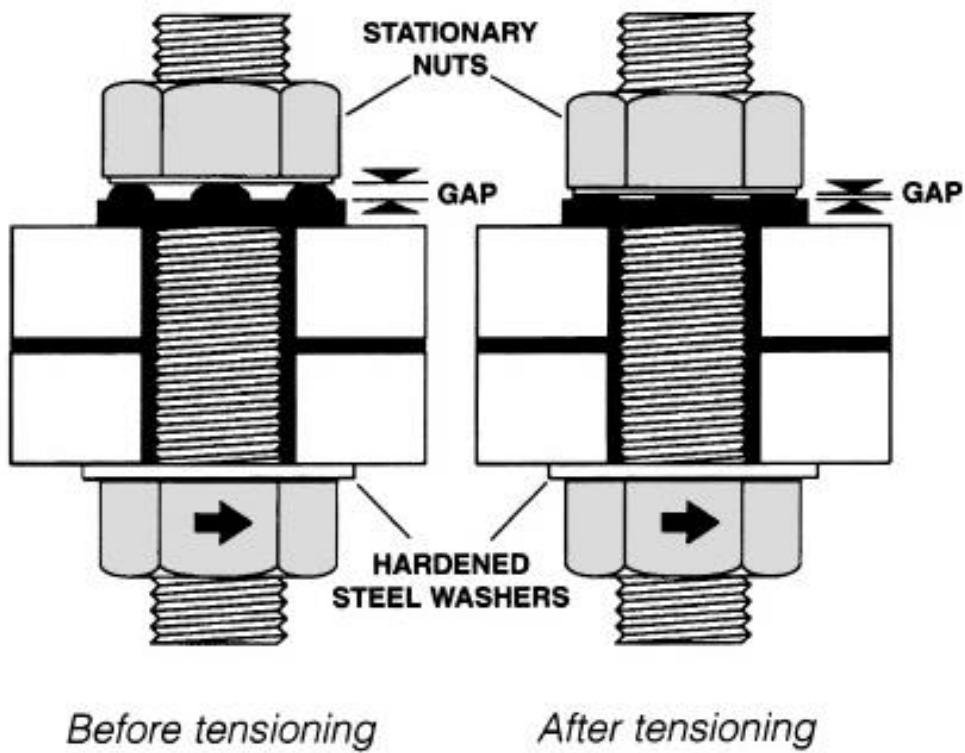

Fig. 6.7: Simple load tension monitoring systems with special washers for anchors (Fastorq, company material)



Fig. 6.8: Expansion shell anchor with two load indicators: 80 kN and 100 kN (Frühwirt et al. 2008)



Fig. 6.9: Anchor with applied DMS for monitoring of axial load (Frühwirt et al. 2008)



Fig. 6.10: Anchor load cell (company material)



Fig. 6.11: Anchor with visual control unit

A simple approach to monitor the anchor load (only visual inspection) is shown in Fig. 6.11. A squeezing ring-shaped steel element is placed between rock mass and anchor nut. Deformation of the ring-shaped element signaled the anchor loading.

7 Design methodologies

A anchor based rock support system can be composed of several layers like illustrated in Fig. 7.1:

Layer 1: systematic rock bolting or rock bolting on demand

Layer 2: retaining elements like steel meshes, shotcrete etc.

Layer 3. cable bolting (long enough to go beyond the failure zone)

Layer 4: external support (structural elements like steel sets, cast concrete lining etc.)

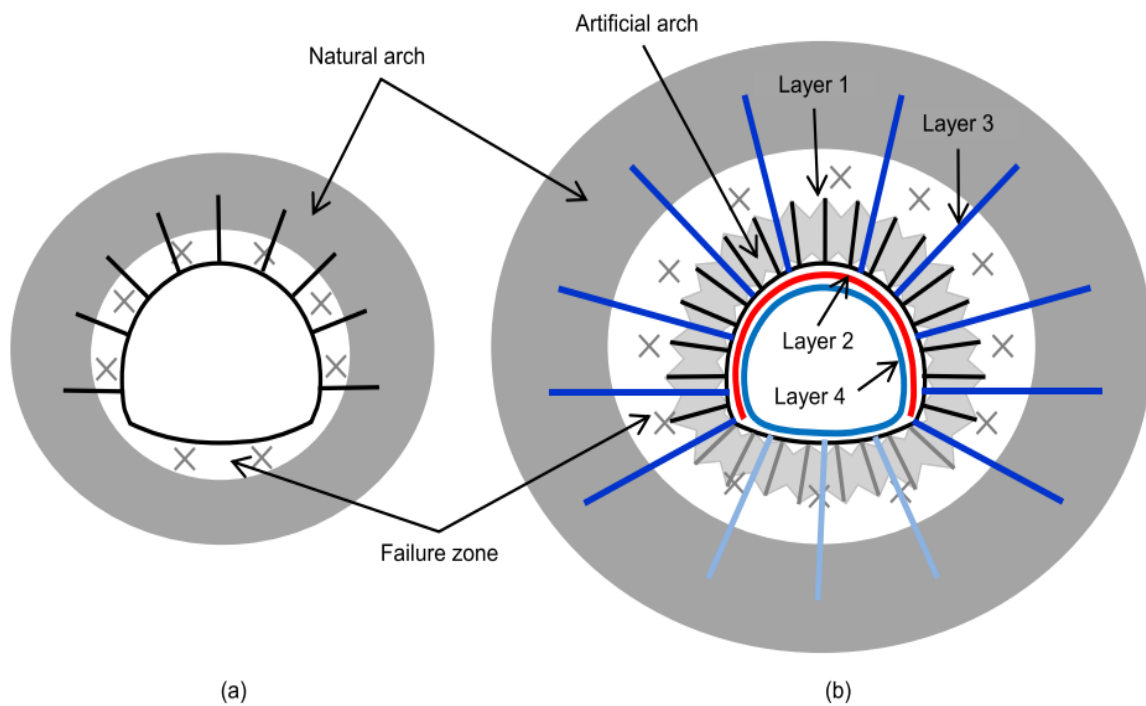

Fig. 7.1: Layered structure of support systems, left: for limited failure zone, right: for large failure zone (Li, 2017)

An anchor based support system can be set-up by one or more anchor types of different length. Fig. 7.2 shows two typical designs for deep metal mines.

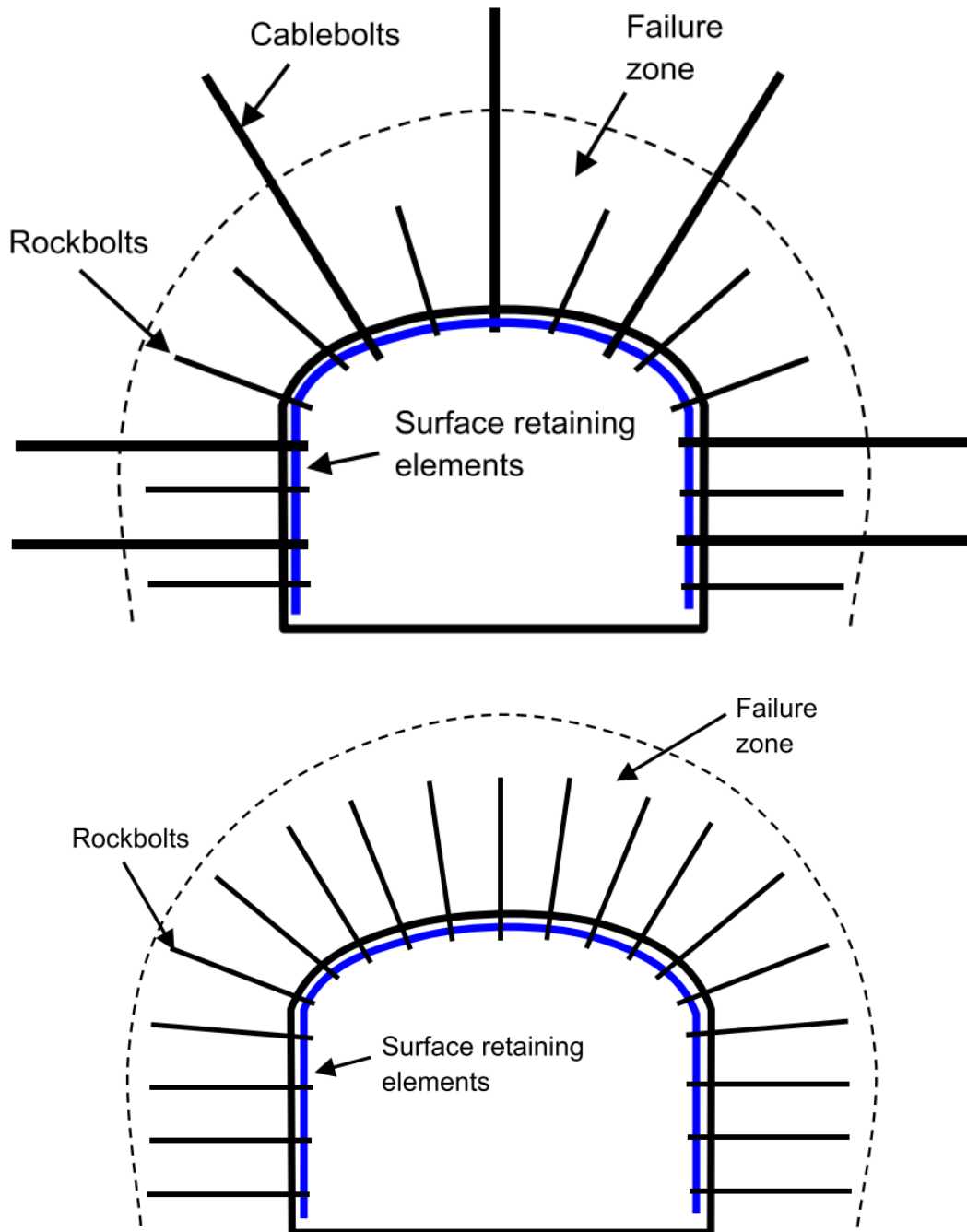

Fig. 7.2: Rockbolting design for deep metal mines, above: Australian approach, below: Canadian and Scandinavian approach (Li, 2017)

8 Anchor installation

Besides manual bolting more and more rock bolting rigs are applied, especially in those cases, where systematic rock bolting is applied (e.g. roof bolting in salt mines). Fully mechanized rock bolting rigs have a bolt magazine and perform positioning, drilling and bolting including fixation of anchor. Two modern rock bolting rigs are shown in Fig. 8.1.



Fig. 8.1: Rock bolting rigs (Atlas Copco, company material)

9 Dimensioning

The dimensioning of anchors and bolts, respectively, includes the specification of the following parameters:

- Anchor length and diameter
- Distance between anchors
- Anchor type
- Fixation of anchor (e.g. type and parameters of grout or resin, expansion shell parameters, pre-tension value, fixation length etc.)

There are 4 different methods used in rock anchors specifications: (i): empirical rules, (ii): special design recommendations, (iii): analytical calculations and (iv): numerical simulations. Some empirical rules are shown in Fig. 9.2, 9.3 and Tab. 9.1. Further information can also be found in E-book no. 11 ('Rock mass classification systems'). Special design recommendations can be found e.g. in special recommendations like 'Ankerrichtlinie' according to Kaliverein (1999). Analytical calculations based on equilibrium considerations of driving and resisting forces and factor of safety calculations (see Fig. 9.1 and E-book no. 19: 'Factor-of-safety calculations in geomechanics') are commonly used. Two- or three-dimensional numerical simulations are the most sophisticated procedures, but allow to take into account complex behaviour or rock mass, anchor and interaction between anchor and rock mass. Explicit numerical simulation of anchors can consider non-linear rock mass behaviour, nonlinear bolt behaviour, nonlinear grout behaviour and pre-tension of bolts. Also, failure of bolts can be simulated. State-of-the-art in numerical anchor simulations for static and dynamic applications in tunnelling and mining is documented e.g. by Hausdorf (2006), Van (2009) or Frühwirt (2008, 2011). Fig. 9.4 to 9.12 give an impression about the potential of numerical simulations of bolting in engineering practice. A simplified way to consider the effect of rock bolting is just to increase strength (e.g. cohesion) in the anchored region.

The following example shows a simple analytical solution based on force equilibrium and considers a potentially sliding rock wedge according to Fig. 9.1. The situation of a potentially failing rock wedge according to Fig. 9.1 is characterised by the following parameters:

- Γ : specific weight of rock mass
 V : volume of rock wedge
 α, β, γ : angles according to fig. 32
 A : pre-stress anchor force
 C : cohesion

If we only consider the force equilibrium and the corresponding factor-of-safety of the rock wedge alone without anchor the following expressions can be deduced:

Driving force: $F_D = \Gamma \cdot V \cos(\beta + \gamma)$

Resisting force: $F_R = \Gamma \cdot V \sin(\beta + \gamma) + C$

Factor-of-safety: $FOS = \frac{F_R}{F_D} = \frac{\Gamma \cdot V \sin(\beta + \gamma) \tan(\phi) + C}{\Gamma \cdot V \cos(\beta + \gamma)}$

If we consider a pre-stressed anchor in addition, the following equations can be obtained:

Pre-stress anchor force parallel to sliding plane: $A_S = A \cos(\alpha - \delta)$

Pre-stress anchor force normal to sliding plane: $A_N = A \sin(\alpha - \delta)$

Factor-of-safety:

$$FOS = \frac{F_R + A_N \tan(\phi) + A_S}{F_D} = \frac{\Gamma \cdot V \sin(\beta + \gamma) \tan(\phi) + C + A \sin(\alpha - \delta) \tan(\phi) + A \cos(\alpha - \delta)}{\Gamma \cdot V \cos(\beta + \gamma)}$$

Based on these equations several answers to practical import questions can be obtained, e.g.:

- Which pre-stress is necessary to reach the desired factor-of-safety?
- Which angle of δ delivers the highest factor-of-safety?

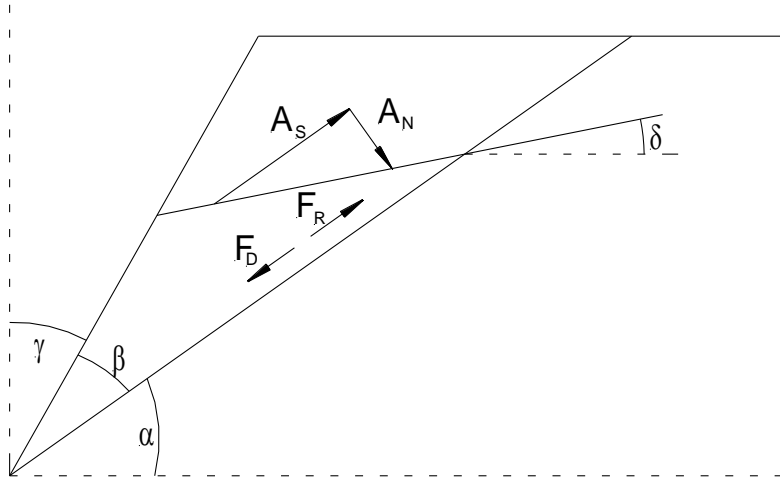

Fig. 9.1: Sketch of potentially failing slope wedge

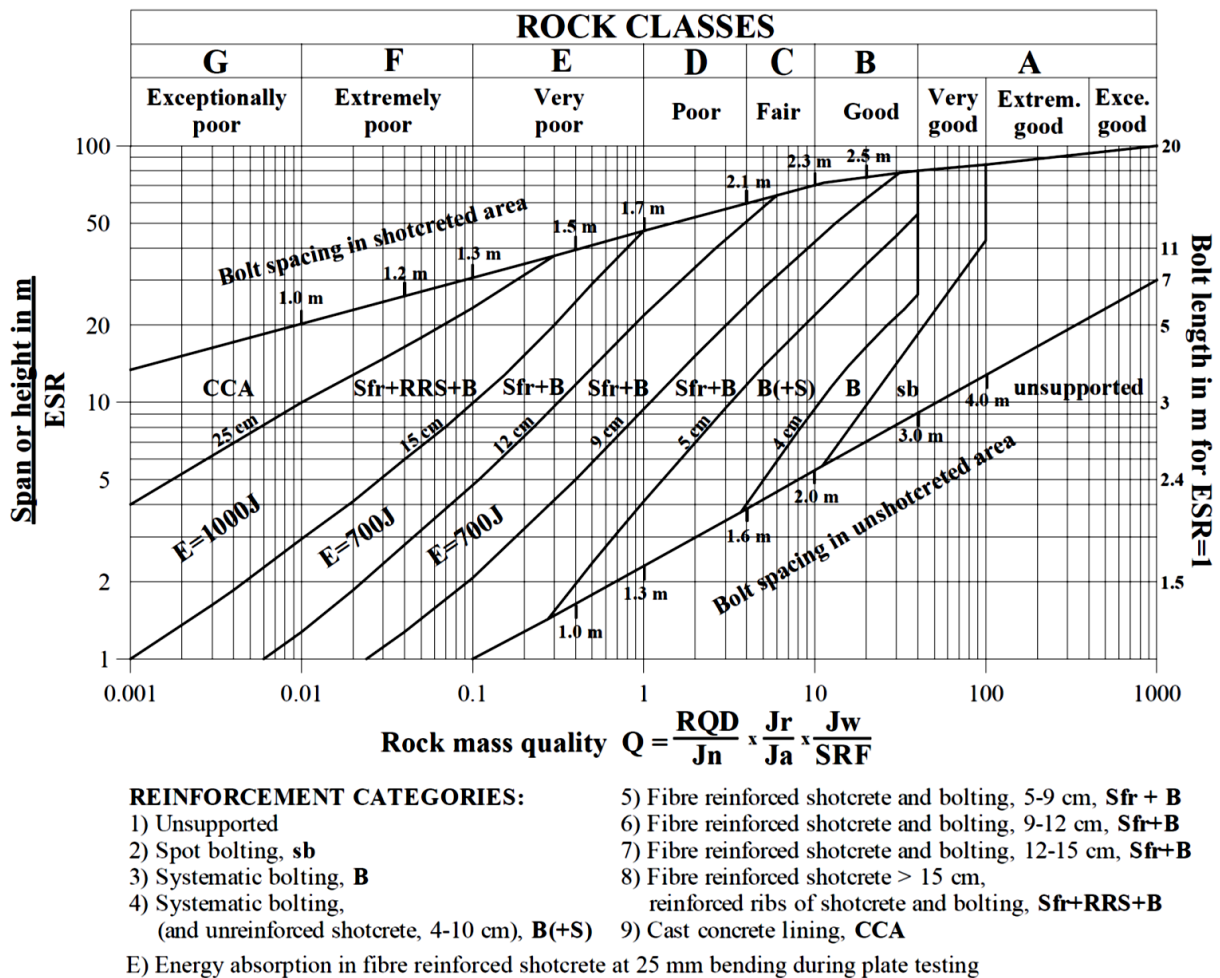

Fig. 9.2: Rock bolt design chart based on Q rock mass classification (Barton et al. 1993)

Rock mass class	Excavation	Support		
		Rock bolts (20 mm in diameter, fully bonded)	Shotcrete	Steel sets
Very good rock I RMR: 81÷100	Full face 3 m advance	Generally no support required except for occasional spot bolting		
Good rock II RMR: 61÷ 80	Full face 3 m advance 1.0÷1.5 m advance Complete support 20 m from face	Local bolts in crown 3 m long, spaced 2.5 m with occasional wire mesh	50 mm crown where required	None
Fair rock III RMR: 41÷ 60	Top heading and bench, 1.5÷ 3 m advance in top heading. Commence support after each blast. Complete support 10 m from face	Systematic bolts 4 m long, spaced 1.5÷2 m in crown and wall with wire mesh in crown	50÷100 mm in crown and 30 mm in sides	None
Poor rock IV RMR: 21÷ 40	Top heading and bench, 1.0÷ 1.5 m advance in top heading. Install support concurrently with excavation 10 m from face	Systematic bolts 4÷5 m long, spaced 1.0÷1.5 m in crown and wall with wire mesh	100÷150 mm in crown and 100 mm in sides	Light to medium ribs spaced 1.5 m where required
Very poor rock V RMR: <20	Multiple drifts, 0.5÷ 1.5 m advance in top heading. Install support concurrently with excavation. Shotcrete as soon as possible after blasting	Systematic bolts 5÷6 m long, spaced 1.0÷1.5 m in crown and wall with wire mesh. Bolt invert	150÷200 mm in crown and 150 mm in sides and 50 mm on face	Medium to heavy ribs spaced 0.75 m with steel lagging and fore-poling if required. Close invert

(Shape: horseshoe; width: 10 m; vertical stress: below 25 MPa; construction: Drilling and blasting).

Fig. 9.3: Guidelines for excavation and support systems in rock tunnels (Bieniawski 1979)

Tab. 9.1: Typical design recommendations for rock bolts according to the US Corps of Engineers (Stillborg, 1994)

Parameter	Empirical rules
1. Minimum length and maximum spacing	
Minimum length	Greatest of: (a) $2 \times$ bolt spacing (b) $3 \times$ thickness of critical and potentially unstable rock blocks (c) For element above the spring line: - Spans < 6 m : 0.5 span - Spans between 18 and 30 m: $0.25 \times$ span - Spans between 6 and 18 m: interpolate between 3 and 4.5 m (d) For element below the spring line: - Height < 18 m: as (c) above - Height > 18 m: $0.2 \times$ height
Maximum spacing	Least of: (a) $0.5 \times$ bolt length (b) $1.5 \times$ width of critical and potentially unstable rock blocks (c) 2.0 m
Minimum spacing	0.9 to 1.2 m
2. Minimum average confining pressure	
Minimum average confining pressure at yield point of elements	Greatest of: (a) Above spring line: Either pressure = vertical rock load of $0.2 \times$ opening width or 40 kN/m^2 (b) Below spring line: Either pressure = vertical rock load of $0.1 \times$ opening height or 40 kN/m^2 (c) At intersection: $2 \times$ confining pressure determined above

Following, some numerical examples for dimensioning are given. Fig. 9.4 illustrates the tensile behaviour of a single expansion shell anchor. The coloured curves in the middle show the simulated force-displacement behaviour (tensile loading with several smaller unloading phases), which reveals three phases: elastic response, onset of plastification and strain hardening. Such an anchor can bear up to about 10 % tensile strain.

Fig. 9.5 illustrates how increasing number of anchors can reduce contour displacements and Fig. 9.6 illustrates, that increasing number of anchors leads to a reduction of individual anchor loads. Fig. 9.7 compares two situations: the left row shows the behaviour of an unsupported drift and the right one the same situation but with anchors in the crown.

It becomes visible that anchors reduce deformations and limit the extension of the plastic zone.

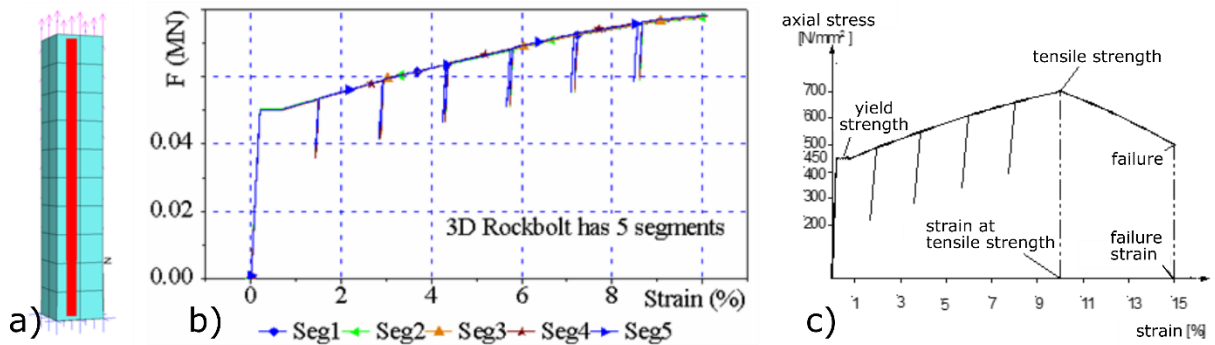

Fig. 9.4: Numerical simulation of multi-segmented bolt element (a) under tension with several loading and unloading cycles (b). (c): standardised stress-strain curve for anchor rod according to Kaliverein (1999)

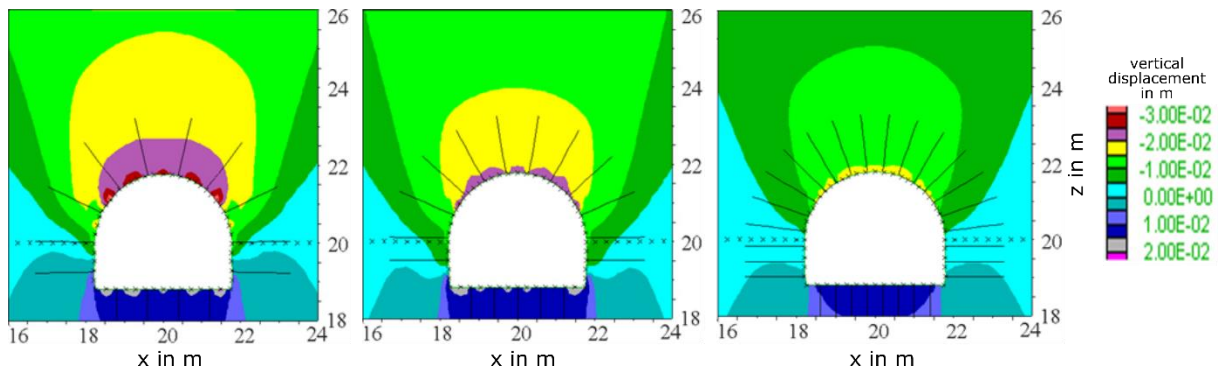

Fig. 9.5: Effect of number of roof anchors on vertical displacement after Van (2008)

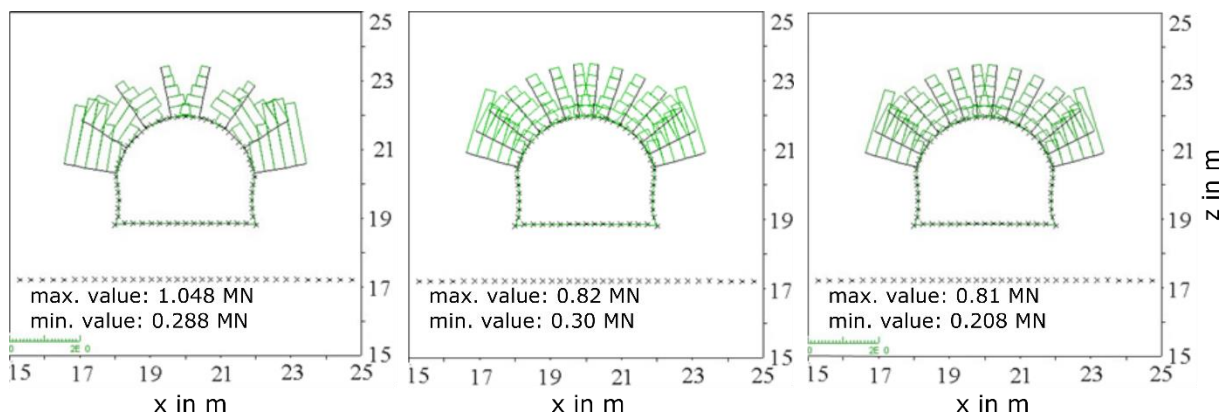

Fig. 9.6: Effect of number of roof anchors: anchor forces after Van (2008)

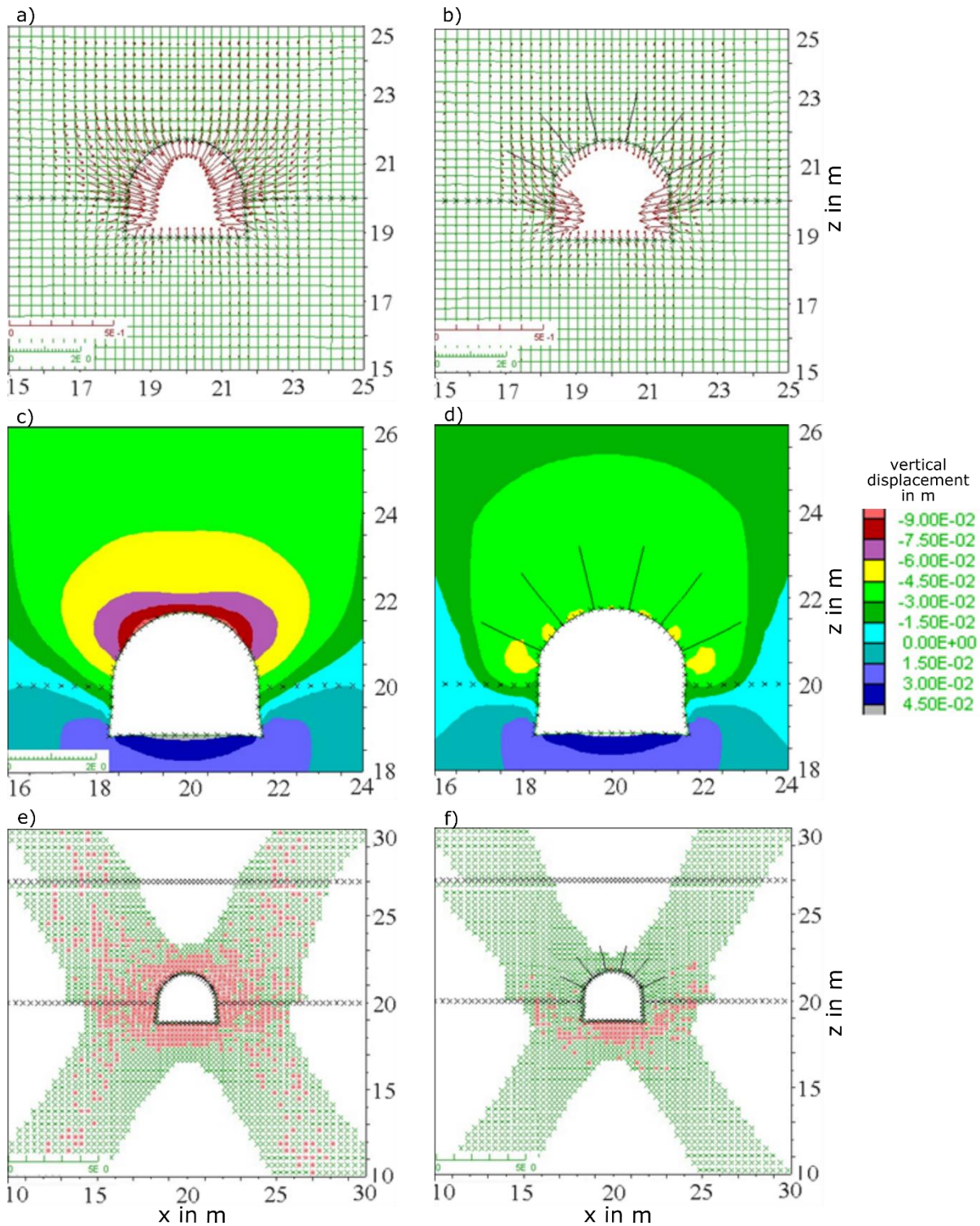

Fig. 9.7: Comparison between bolted and unbolted drift: a)+b): displacement vectors, c)+d): contours of vertical displacement magnitude, e)+f): plasticity state (red = active plastification) after Van (2008)

Fig. 9.8 illustrates the anchor forces in case of fully grouted anchors installed to stabilise a slope. This figure also shows that the slope would fail if no anchors are installed. Fig. 9.9 illustrates a similar situation, but here the slope is stabilized with only partially grouted anchors. Therefore, axial forces inside the anchors develop nearly only in those parts which are not fixed to the rock mass.

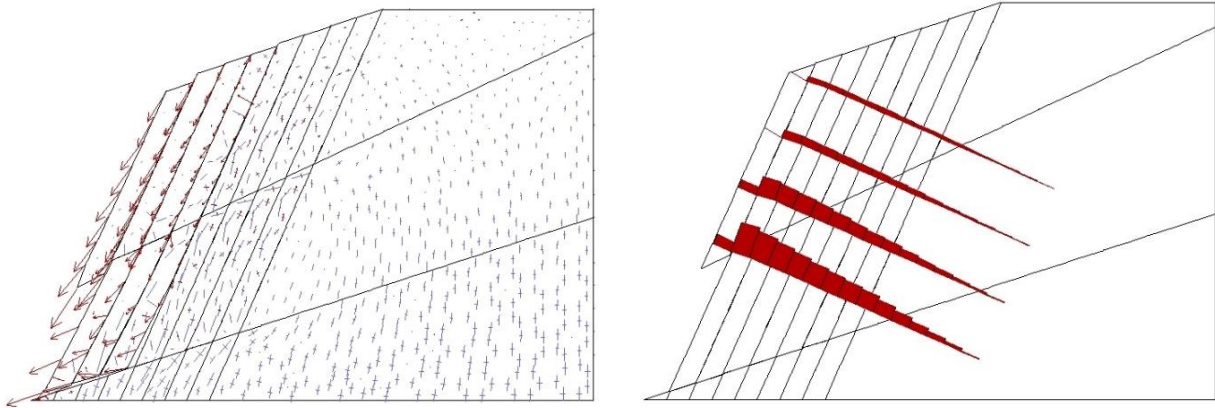

Fig. 9.8: Slope without and with fully grouted bolting, Left: slope at failure with displacement vectors; Right: stabilized slope with calculated axial anchor forces

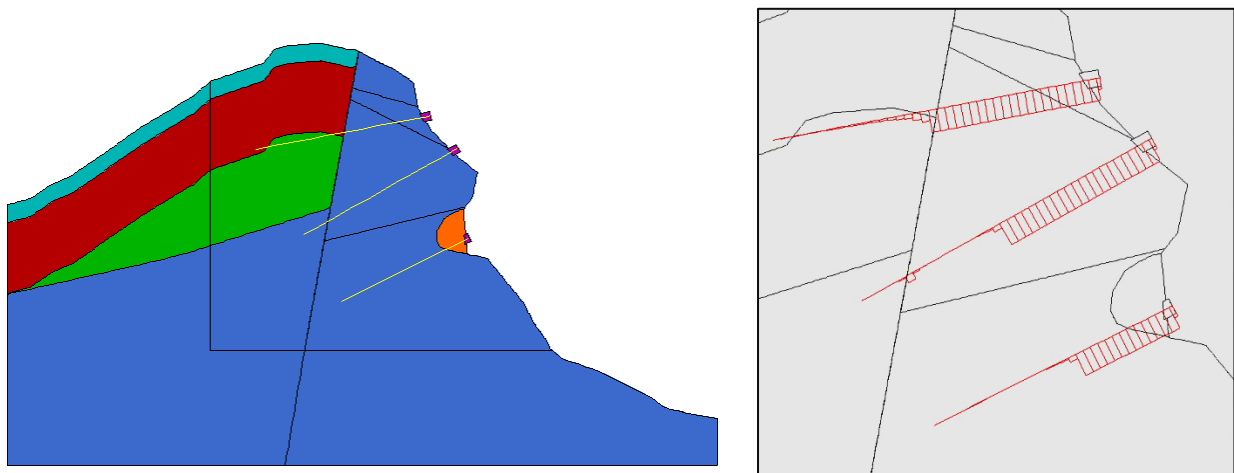

Fig. 9.9: Slope with pre-tensioned anchors, Left: numerical slope model design; right: detail with calculated axial anchor forces

Fig. 9.10 shows an open air theatre called “Felsenbühne Rathen” in Saxony, Germany. Directly above the stage an overhanging rock block (sandstone) had to be stabilized. Due to environmental restrictions a minimal invasive stabilization technology had to be applied. This was reached by the procedure shown in Fig. 9.11. Very precise drilling was necessary starting from an excavation pit above the stage (no tree was cut). The optimum pre-stress of the three anchors was determined via numerical modelling (Konietzky, 2000; see Fig. 9.12) and is monitored already for about 20 years. So far the system is stable and pre-stress is not released.



Fig. 9.10: Location of open air theatre “Felsenbühne Rathen”, in the background above the stage the said overhanging rock block (Konietzky, 2000)

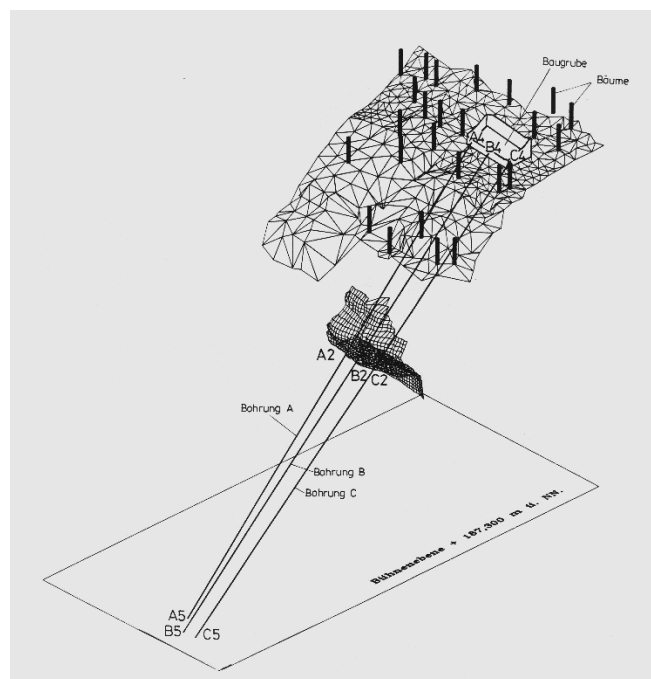
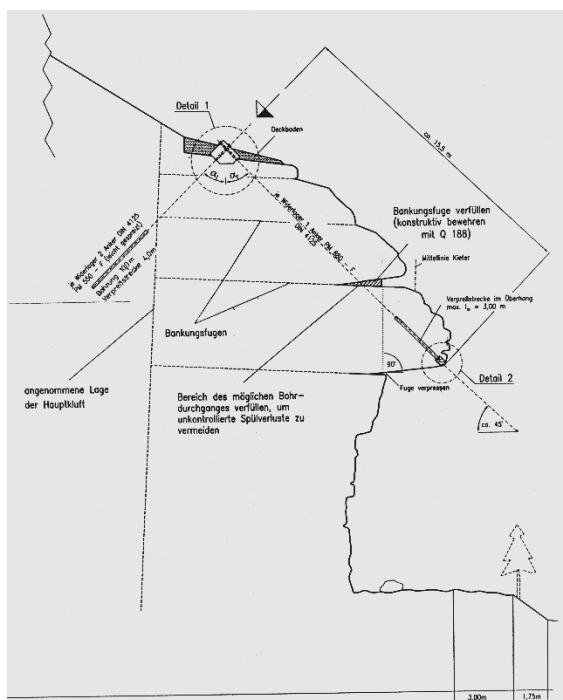

Fig. 9.11: Anchor design (3 anchors) to stabilize the overhanging rock block (Konietzky, 2000)

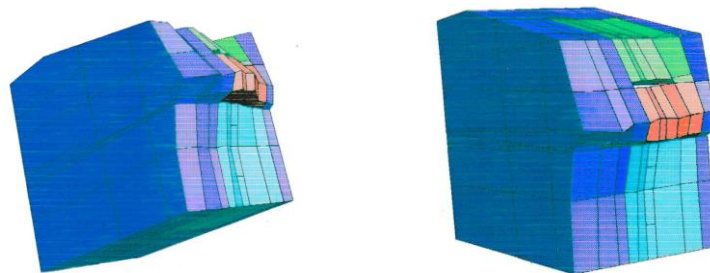

Fig. 9.12: Numerical model to determine optimum pre-stress for anchors (Konietzky, 2000)

10 Literature

- Barton, N. et al. (1993): Updating of the Q-System for NMT, Proc. Int. Sym. on Sprayed Concrete, Norwegian Concrete Association
- Bieniawski, Z.T. (1979): Rock mass classification in rock engineering, Proc. Exploration for Rock Engineering, A.A Balkema, 97-106
- Chen, Y. (2014): Experimental study and stress analysis of rockbolt anchorage performance, J. Rock Mechanics and Geotechnical Engineering, 6: 428-437
- DSI (2015): Mechanical Anchors and Rebar Rock Bolts,
Retrieved from (May 2018):
https://static1.squarespace.com/static/529f28d4e4b0cf8c82ff287b/t/52acf49be4b0e46ab625d265/1387066523589/DSI-ALWAG-Systems_Mechanical-Anchors-and-Rebar-Rock-Bolts.pdf
- Frühwirt, T. (2011): Das Tragverhalten der Firstankerung beim Abbau von flach einfallenden Kaliflözen unter besonderer Beachtung dynamischer Beanspruchungen, Publication Geotechnical Institute, TU Bergakademie Freiberg, Ed.: H. Konietzky, Heft 2011-1
- Frühwirt, T. et al. (2008): State-of-the-art and recent developments in monitoring and numerical modelling of roof bolting in potash mines of the K+S group, Publ. Geotechnical Institute, TU Bergakademie Freiberg, Ed.: H. Konietzky, Heft 2008-3, p.81-93
- Hausdorf, A. (2006): Numerische Untersuchungen zur Stabilität von Kammerfirsten im Salzbergbau unter besonderer Beachtung eines Systemankerung, Publication Geotechnical Institute, TU Bergakademie Freiberg, Ed.: H. Konietzky, Heft 2006-2
- He, M. et al. (2014): Development of a novel energy-absorbing bolt with extraordinarily large elongation and constant resistance, Int. J. Rock Mech & Mining Sci., 67: 29-42
- Hosseini, J. (2006): A new approach in determining the load transfer mechanism in fully grouted bolts, Dissertation, University of Wollongong, Australia
- Hudson, J.A. (Ed. / 1993): Comprehensive Rock Engineering, Vol. 4, Pergamon Press
Kaliverein (1999): Grundsätze zur Beurteilung und Verwendung von Ankerbau zur systematischen Firstsicherung im Kali- und Steinsalzbergbau (Ankerrichtlinie)
- Li, C. (2008): Laboratory testing and performance of rock bolts, Publication Geotechnical Institute, TU Bergakademie Freiberg, Ed.: H. Konietzky, Heft 2008-3, p. 47-58
- Li, C. (2010): A new energy-absorbing bolt for rock support in high stress rock masses, Int. J. Rock Mech & Mining Sci., 47: 396-404
- Li, C. (2017): Principles of rockbolting design, IJRMGE, 9(3): 396-414
- Junker, M. et al. (2006): Gebirgsbeherrschung von Flözstrecken, Verlag Glückauf, 656 p.
- Konietzky, H. (2000): Anchor dimensioning for the open air theater „Felsenbühne Rathen“, unpublished report

- Kristijansson, G. (2014): Rock bolting and pull out test on rebar bolts, Dissertation, NTNU Trondheim, Norway
- Malkowski, P. et al. (2023): Laboratorial tests and numerical modelling of rock bolts bonded by different materials, *Rock Mech. Rock Eng.*, 56: 2589-2606
- Rocscience (2015a): Rockbolts and cables,
Retrieved from (May 2018) https://www.rocscience.com/documents/hoek/corner/15_Rockbolts_and_cables.pdf
- Rocscience (2015b): Factors influencing the effectiveness of split set friction stabilizer bolts, Retrieved from (May 2018): <https://rocscience.com/documents/pdfs/uploads/9157.pdf>
- Skrzypkowski, K. (2018): Laboratory testing of a long expansion rock bolt support for energy-absorbing applications, *W3S Web Conferences* 29, 00004
- Stillborg, B. (1994): Professional users handbook for rock bolting, 2nd Edition, Clausthal-Zellerfeld: Trans Tech Publications.
- Van, Cong Le (2008): Numerical analysis of the interaction between rock bolts and rock mass for coal mine drifts in Vietnam, Publication Geotechnical Institute, TU Bergakademie Freiberg, Ed.: H. Konietzky, Heft 2009-2